

Immersion Separators CV-NA7

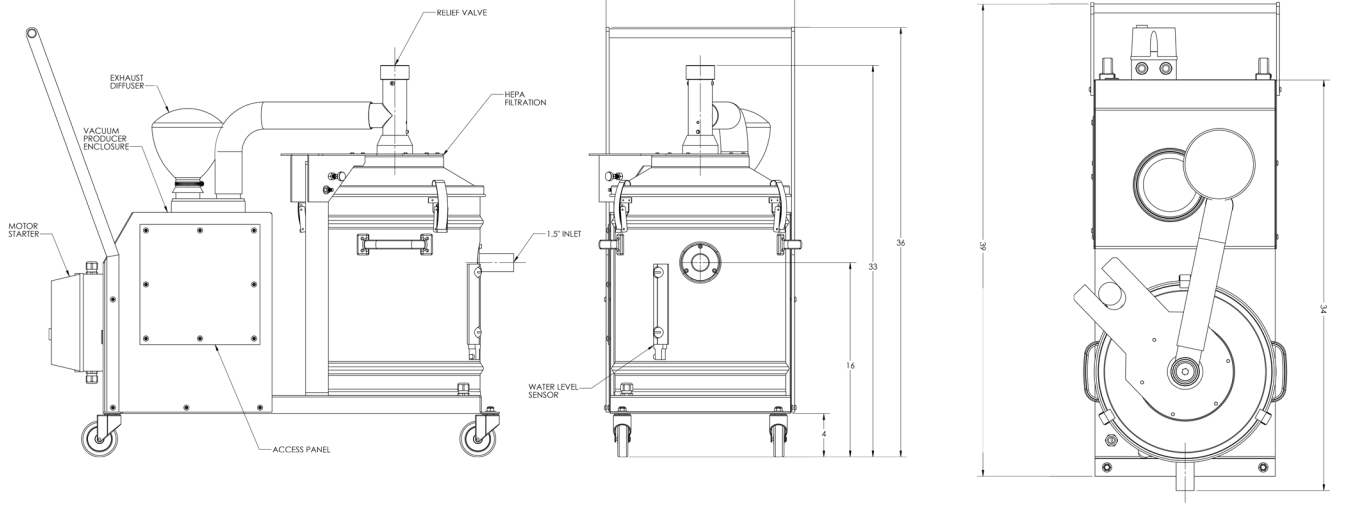

SEPARATION SYSTEMS



CV-NA7 Standard Specifications

- 1 HP, 110 Volt, 13 Amps continuous duty motor
- Stainless steel vessel safely collects and neutralizes explosive or glowing media
- Turbulent liquid bath and water mist filter particulate contents moving within vacuum using a rapidly moving air source and submersion
- Filter monitor sensor and external Lexan sight glass easily monitors water and debris levels
- Optional 50 Micron filter bag for collection of sludge / liquid
- Hydrogen relief valve allows for escape of hazardous gas
- Silencer enclosure for quiet operation - 62 dBA
- Top access lid for easy maintenance
- Includes 10' x 1.5" static-conductive hose (#359810) and 1.5" conductive rubber nozzle (#35655)

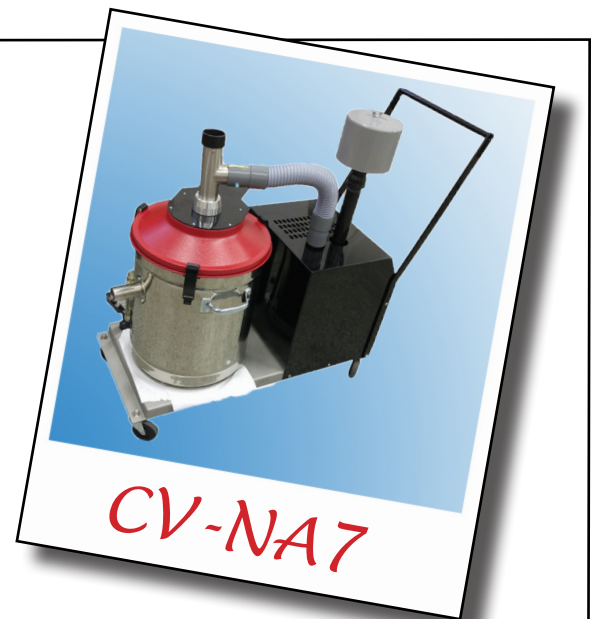

Base Price: Call for Pricing