

REDLINE BAGGER

INTERMITTENT DUTY GENERAL HOUSEKEEPING SERIES

STANDARD SPECIFICATIONS: **RB350** NEW DOUBLE STACK DESIGN

- Three Motor - 220/1/60, 350 CFM, 5Hp and 91" H2O
- Compression Cast **"Bulletproof"** Composite Modular Housing
- External Filter Cleaning Mechanism - Dustless Cleaning of Filter
- 28 ft² MicroClean Filter - 99% Efficient @ 0.5 Microns - 3 Year Guarantee
- HEPA 2.0 - 99.97% Efficient @ .3 Microns
- 2.75" Vacuum Inlet with Aluminum Cast Deflector
- Intermittent Duty Operation
- Direct Bagging Collection Style
- Use up to 50' Feet of Hose

*Formerly the WNS2320-DB 220v

RB350
HEPA 2.0



USE UP TO 50' OF HOSE!

INCLUDES RUWAC **3 YEAR FILTER GUARANTEE!**

www.ruwac.com
Ruwac USA

THE FINE DUST EXPERTS

CONTACT US TODAY FOR PRICING AND AVAILABILITY

413-532-4030

AVAILABLE UPGRADES:

- HEPA Maxx Filter
99.997% Efficient @ .3 Microns
- 32" Floor Sweep
- Dust Extraction Arm
- **LongoPac**® Bagging System

Ruwac

INDUSTRIAL VACUUM SOLUTIONS

RB350

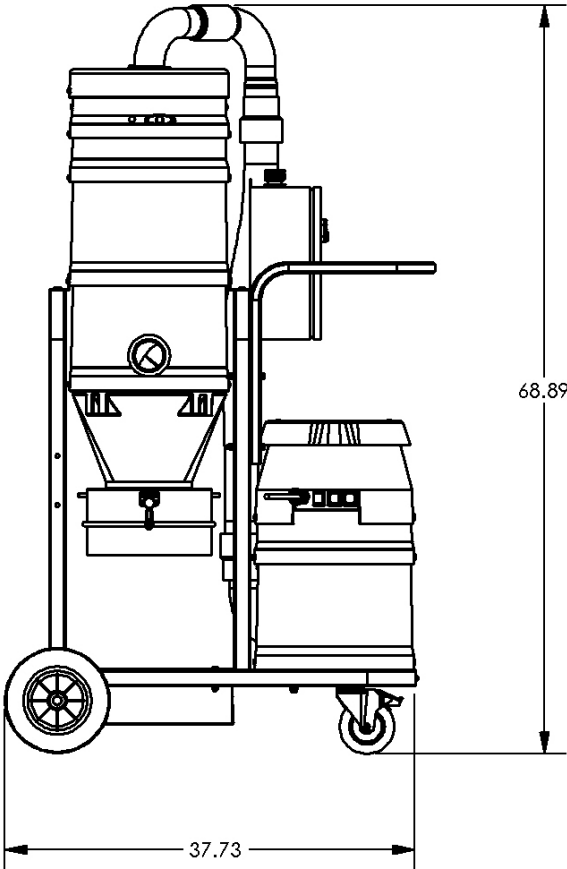
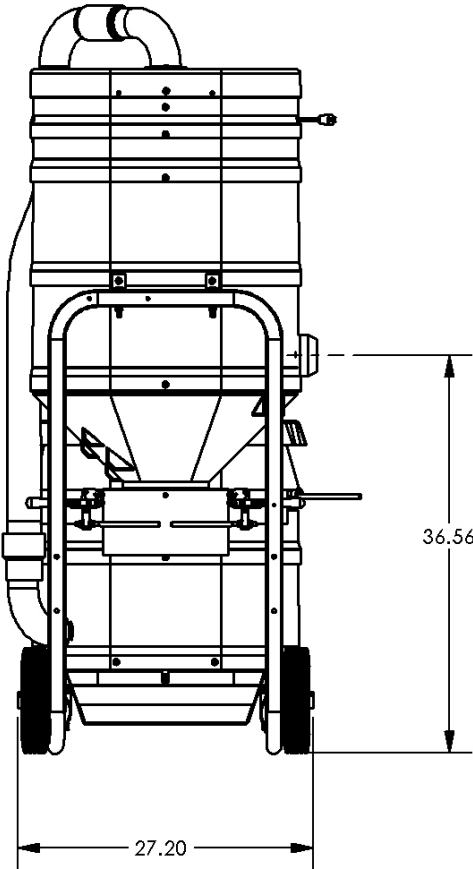

*Shown with Optional Power Distribution box