

# HEPA 2.0 FILTER UPGRADE

**PURIFY AIR WHILE KEEPING WORKERS SAFE FROM HARMFUL DUST!**

**BEFORE HEPA**

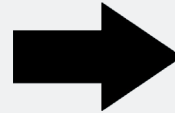
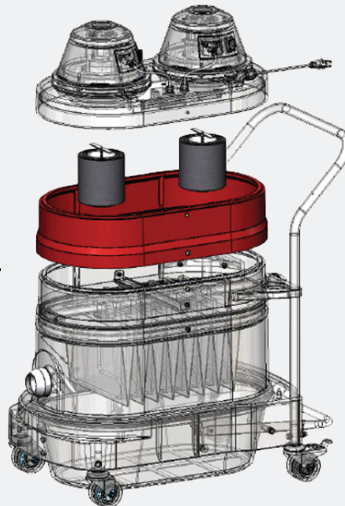
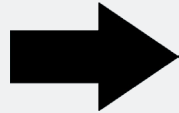
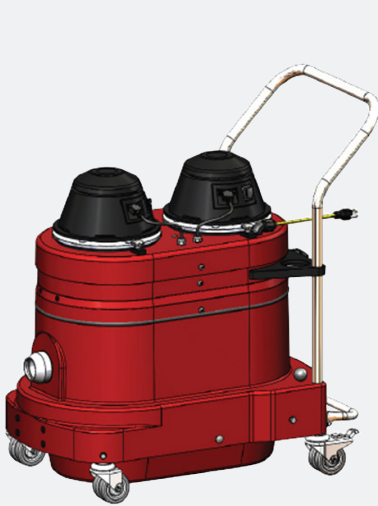

**AFTER HEPA**



**PROVIDES A CLEANER WORK ENVIRONMENT!**

If your material requires an additional level of filtration to ensure workers are kept safe from dangerous contaminants like silica dust, the HEPA 2.0 filter upgrade is your absolute solution. These HEPA filters are compliant to OSHA's silica dust standards, and are easy to install onto your R151, R201, R211, or R291 vacuum system. Best of all, they serve to full-proof the vacuum's existing primary MicroClean filtration system. MicroClean filters are industry-leading and already compliant to OSHA's silica standards for dust collectors. At 99.9% efficient @ 0.5 microns, they allow very few particles to get past their initial filtration process. The HEPA 2.0 filter's additional 99.97% @ 0.3 microns efficiency will ensure ultimate filtration that complies with all of OSHA's silica dust standards.

## #35191CON / 35192CON / 3519203CON Features

- MERV 17 at 99.97% @ 0.3 microns
- Modular construction makes them easy to install and upgrade
- Finite filtering purifies air
- Compliant to OSHA's silica dust collection standards

