

HIGH EFFICIENCY

HEPA

PARTICULATE AIR
MAXX

FILTER UPGRADE

MAXIMUM AIR PURIFICATION FOR THE TOUGHEST DUST REMOVAL JOBS

BEFORE HEPA

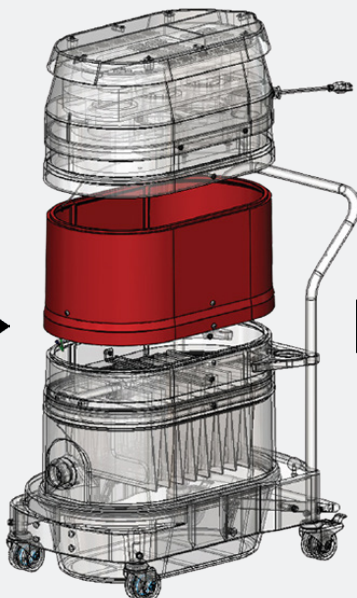

AFTER HEPA

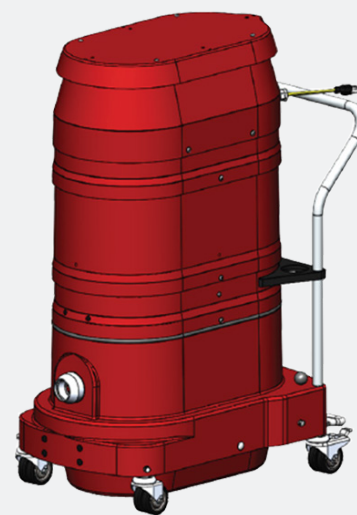

PROVIDES A CLEANER WORK ENVIRONMENT!

For materials requiring the ultimate level of filtration for air purification and keeping workers safe from dangerous contaminants, Ruwac's HEPA Maxx is your easy-to-install solution that takes it to the extreme. Ruwac already builds all of its industrial portable vacuum cleaners using our innovative MicroClean primary filter. At 99.9% efficient @ 0.5 microns, very few particles get past the initial filtering process, but with the HEPA Maxx's MERV 17 at 99.97% at 0.3 micron rating, purified air return is practically guaranteed while providing a cleaner work environment.

#35192 / 35193 Features

- MERV 17 at 99.97% @ 0.3 microns
- Modular construction makes them easy to install and upgrade on any Red Line, Workhorse, or Alternative Power Series vacuum
- Finite filtering purifies air
- Individually DOP certified
- Minihelic filter monitoring
- Oversized filter and housing with velocity reduction chamber
- Bottom seal positive gasket
- Average HEPA Maxx lifespan: 5 - 7 years (w/ the use of Ruwac's MicroClean primary filter)

