

### HEPA MAXX FILTER CONVERSION KIT

#35192	Standard	List: \$942.08
#35192S01	Compact	List: \$1,026.29

- For use with a Red Line Series vacuum
- MERV 17 at 99.97% @ 0.3 microns
- Finite filtering purifies air
- Individually DOP certified
- Minihelic filter monitoring
- Oversized filter and housing with velocity reduction chamber
- Bottom seal positive gasket
- For use with Abatement, Nuclear, Hospitals, and other applications that require maximum air purification
- Compliant to OSHA's silica dust collection standards

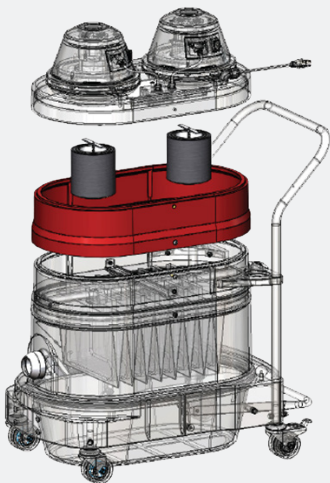
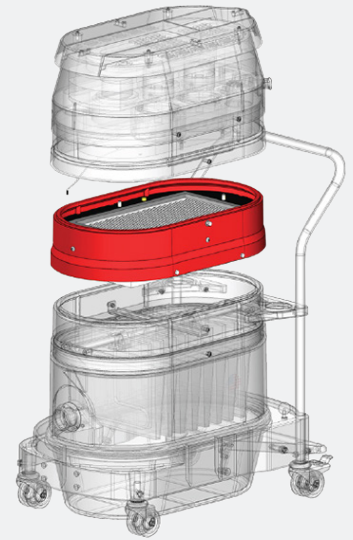

### HEPA 2.0 FILTER CONVERSION KIT

#35191CON	1 Filter for R151	List: \$336.83
#35192CON	2 Filters for R201 & R211	List: \$442.09
#3519203CON	3 Filters for R291	List: \$552.62

- MERV 17 at 99.97% @ 0.3 microns
- Modular construction makes them easy to install and upgrade
- Finite filtering purifies air
- Compliant to OSHA's silica dust collection standards



### DIRECT BAGGER VACUUM CONVERSION KIT

#565301KIT	2" Inlet for RB201 and RB211	List: \$1,678.90
#565370KIT	2.75" Inlet for RB291	List: \$1,710.47

- Turns your Ruwac portable RB201, RB211 or RB291 vacuum into a direct bagging system without the expense of buying an entirely new machine
- Easy to install -- Simply requires the removal of the motor deck, filter and shaker systems from your portable vacuum, and installing it onto the Direct Bagger vacuum conversion frame
- Option to convert vacuum back to portable for various other vacuuming applications

