

# Ruwac USA Industrial Vacuums

MX300 / MX300EX / MX360 / MX360EX Series

(Formerly NA35 / NX35 EX / NA35-HD / NA35-HD EX Series)

Installation, Operation, Maintenance & Service

Model No.

Serial No.

Filter No.

Start-Up Date

## IMMERSION SEPARATION VACUUMS



Version: 3.1 3/1/24

<b>Contents</b>	<b>Page</b>
I. Warranty	3
II. Safety	3
III. Start-Up	14
IV. Inspection and Maintenance	18
Air-Powered Instructions	29
Electric Instructions	29
V. Trouble Shooting	35
VI. Terms and Conditions	36
Appendix	39

## I. Warranty

RUWAC warrants that new equipment which are complete units and are sold and/or manufactured by RUWAC, Inc. will be free from defects in material and workmanship for a period of 18 months from date of shipment or 12 months from date of start-up, whichever come first. RUWAC warrants that replacement parts sold hereunder will be free from defects in material or workmanship for a period of 120-days after the date of shipment. RUWAC machines that have been completely re-built at the factory will carry a 180-day warranty from date of shipment. All field repairs preformed by authorized RUWAC service personnel are covered by a 120-day parts only warranty.

RUWAC, Inc. will not assume any responsibility under the terms of this limited warranty on equipment, which has not been paid in full. This warranty does not apply to any equipment that has been disassembled, repaired, or otherwise altered by any person without the written authorization of RUWAC'S service department, nor does it apply to any product that has been subjected to failure sure to corrosive or abrasive attack, misused, damaged, or improperly installed, nor does it apply to motors, controls, and components not manufactured by RUWAC, Inc. Motors, controls, and other Sub vendor's components therefor are warranted only to the extent of the manufacture's warranty. All warranty work on such products must be authorized by RUWAC, Inc. and must be performed in an authorized shop as designated by the manufacturer. RUWAC sole liability and buyer's sole and exclusive remedy hereunder is the replacement or repair at RUWAC'S option of products not complying with this warranty. Such repair or replacement shall be F.O.B. RUWAC'S factory, and RUWAC reserves the right to invoice all expenses incurred when repairs are made in the field at the request of the customer, except as specifically set forth herein, RUWAC makes no warranty express or implied, with respect to the products and/or service supplied hereunder, this warranty is in lieu of and excludes all other warranties, including without limitation, any warranty of merchantability, fitness for a particular purpose, or conformance to purchaser's specifications.

## II. Safety

**CAUTION:** Standard Ruwac MX series motor decks are designed for continuous use provided the vacuum is not held under constant stress. If you are unsure about your application requirements consult your Ruwac representative.

**CAUTION:** Always check that the motor is rotating in the indicated direction upon start-up. Power polarity can change from power supply to power supply. Operation under a reversed polarity will damage the motor, the turbine and/or the machine.

**CAUTION:** Disconnect the machine from the power source before and during inspection and/or maintenance.

**CAUTION:** The components in this machine can be very heavy. Always follow safe lifting procedures.

**CAUTION:** Allow at least three feet of clearance space above the unit to safely remove or install components.

**CAUTION:** Make absolutely sure that there are no unsecured objects above the filter after maintenance or inspection. Catastrophic failure is likely to occur, if an object passes through the turbine while running.

**CAUTION:** This separation system is designed for the separation of sensitive ultra-fine materials. It may also be used for the neutralization of hot or glowing media; however, it may not be used for both materials simultaneously.

**CAUTION:** The electrical service at the installation site must supply the voltage stamped on the machine's serial tag. Most motors have multiple voltage capabilities that may appear on the motor serial tag but do not apply to the machine. Operating at an incorrect voltage may damage the machine.

**CAUTION:** Only Ruwac explosion proof accessories should be used alongside your MX300 / MX300EX / MX360 / MX360EX unit. Using any other accessories will compromise the grounding of your machine, potentially rendering it defenseless against safe collecting combustible dust and creating a dangerous environment.

**CAUTION:** Perform a ground continuity test on your MX300 / MX300EX / MX360 / MX360-EX unit before each use.

**CAUTION:** Per current NFPA 484 guidelines this machine is equipped with a method of grounding/bonding that is independent of the facility electrical system.

**CAUTION:** Before each use the operator must perform a continuity test using line ground, additional mandatory grounds and any/all accessories that are connected to the machine.

## **IMPORTANT SAFETY INSTRUCTIONS**

When using an electrical appliance, basic precautions should always be followed, including the following.

### **READ ALL INSTRUCTIONS BEFORE USING THIS APPLIANCE**

**The Ruwac MX300 / MX360 is designed for use in hazardous (classified) locations rated: Class II, Division 2, Groups F & G, Zone 22 Group IIIB, T3B/T3C, Max ambient +40 C.**

**The Ruwac MX300EX / MX360EX is designed for use in hazardous (classified) locations rated: Class I Group D, Class I Zone 1 Group IIA, Class II Groups E, F & G, Zone 21 Groups IIIC & IIIB, T3B/T3C, Max ambient +40 C.**

**WARNING** - To reduce the risk of fire, electric shock or injury:

1. Do not leave appliance when plugged in. Unplug from outlet when not in use and before servicing.
2. Use only for the pickup of dry settled material. Do not use for the pickup of liquids.
3. Do not use outdoors or on wet surfaces.
4. Use only as described in the manual. Use only manufacturer recommended attachments.
5. Do not use with damaged cord or plug. If appliance is not working as it should, has been dropped, damaged, left outdoors, or dropped into water, return it to a service center.
6. Do not pull or carry by cord, use cord as a handle, close a door on cord, or pull cord around sharp edges or corners. Do not run appliance over cord. Keep cord away from heated surfaces.
7. Do not unplug cord by pulling on cord. To unplug, grasp the plug, not the cord.
8. Do not handle plug or appliance with wet hands.
9. Do not put any objects into openings. Do not use with any opening blocked; Keep free of dust, lint, hair, and anything that may reduce air flow.
10. Keep hair, loose clothing, fingers, and all parts of body away from openings and moving parts.
11. Turn off all controls before unplugging.
12. Do not use to pick up flammable or combustible liquids, such as gasoline.
13. Make sure that this vacuum is connected to the proper voltage, phase and frequency as stated on the equipment label.
14. Ensure that the ignition temperature of the material being vacuumed is above that of the operating temperature of the motor.

## **SAVE THESE INSTRUCTIONS**



## IMPORTANT SAFETY INSTRUCTIONS (cont'd)

When using an electrical appliance, basic precautions should always be followed, including the following.

### READ ALL INSTRUCTIONS BEFORE USING THIS APPLIANCE

15. Pay special attention to the reactive properties of the material being vacuumed. Ensure that the material is not reactive with other materials present in the machine or its materials of construction. Check your MSDS carefully for special hazards.
16. Do not operate this vacuum with missing or damaged filters.
17. Inspect the vacuum for visible damage, especially to the power cord and cord cap. The vacuum must be removed from service and repaired prior to use.
18. Use only Ruwac replacement parts, accessories and hoses specifically designed for your machine.
19. The MX300 / MX300EX / MX360 / MX360 EX is a continuous duty point of source extraction system with casters provided for easy transportation and emptying.
20. When intended for use in hazardous locations (UL1203), this vacuum is not supplied with a cord cap (unless specifically requested). The cord cap must be selected and installed by a qualified electrical technician. Insure that it is rated for the location, voltage, amperage and phase of the vacuum. Use only twist lock style cord caps.
21. When intended for use in non-hazardous locations (UL 1017), Ruwac will install a UL listed cord cap. It is rated for the location, voltage, amperage and phase of the vacuum. Have an electrician verify the proper motor rotation direction.
22. The vacuum is supplied with a 30 foot power cord. It is absolutely critical that if an extension cord is added that it has the same rating ie. SOOW as the power cord provided and is properly sized to prevent voltage drop to the vacuum. A time delay fuse is necessary to start the vacuum on single phase units.
23. Connect to a properly grounded outlet only. See Grounding Instructions.
24. When the vacuum is in use, be careful that the cord is not laying in an area where it can be rolled over and / or tripped on. Do not lay the cord in a wet area.
25. When not using the vacuum, coil the cord around the handlebar so that it is completely off the ground. Store the vacuum in a dry area.
26. The serial # of your vacuum contains information to identify when your unit was manufactured. The first two digits represent the year, the second two digits represent the month, and the remaining digits represent the sequential unit manufactured that year. Please have your serial # ready when contacting Ruwac about your unit.
27. Hoses and accessories must be checked for continuity prior to each use when used in a hazardous application (i.e. combustible materials or environment).

### SAVE THESE INSTRUCTIONS

## **IMPORTANT SAFETY INSTRUCTIONS (cont'd)**

### **READ ALL INSTRUCTIONS BEFORE USING THIS APPLIANCE**

The Ruwac MX300 / MX360 is designed for use in hazardous (classified) locations rated: Class II, Division 2, Groups F & G, Zone 22 Group IIIB, T3B/T3C, Max ambient +40 C.

The Ruwac MX300EX / MX360EX is designed for use in hazardous (classified) locations rated: Class I Group D, Class I Zone 1 Group IIA, Class II Groups E, F & G, Zone 21 Groups IIIC & IIIB, T3B/T3C, Max ambient +40 C.

## **CAUTION!**

**TO REDUCE THE RISK OF FIRE, ELECTRIC SHOCK, OR INJURY**

1. Make sure that this vacuum is connected to the proper voltage, phase and frequency as stated on the equipment label.
2. Use only for the pickup of dry settled material. Do not use for the pickup of liquids.
3. Always maintain liquid level.
4. Pay special attention to the reactive properties of the material being vacuumed. Insure that the material is not reactive with other materials present in the machine or its materials of construction. Check your MSDS carefully for special hazards.
5. Do not operate this vacuum with missing or damaged filters.
6. Inspect the vacuum for visible damage, especially to the power cord and cord cap. The vacuum must be removed from service and repaired prior to use.
7. Unplug the vacuum from the power source when not being used or when being serviced.
8. Connect to grounded dedicated circuits only.
9. Do not use the power cord to move this vacuum.
10. This vacuum is not designed for outside use or use in wet applications.
11. The vacuum's base should be emptied after each use. Do not store vacuum with process material and / or liquid still in the base.

**SAVE THESE INSTRUCTIONS**

## **IMPORTANT SAFETY INSTRUCTIONS (cont'd)**

### **READ ALL INSTRUCTIONS BEFORE USING THIS APPLIANCE**

#### **WARNING:**

The electrical service at the installation site must supply the voltage stamped on the machine's serial tag. Most motors have multiple voltage capabilities that may appear on the motor serial tag but do not apply to the specific machine. Operating at an incorrect voltage may damage the machine. The machine should be connected to a dedicated fused service and properly grounded. This unit requires a time-delay fuse (20A) for use with single-phase power.

#### **WARNING:**

A qualified electrician in accordance to the NATIONAL ELECTRIC CODE and all local codes should perform all wiring and or electrical adjustments during installation and servicing.

1. Install the proper cord cap on the power cable following the manufacturer's instructions. Insure that all terminal screws are properly tightened.
2. Start the machine by turning the selector to the ON position noting the motor direction. If the motor is turning in the wrong direction, shut the machine off by turning the selector to the OFF position. Have your electrician rewire the cord cap to correct the motor rotation.

#### **WARNING:**

**When using the vacuum in another location, always verify motor rotation before placing the vacuum into service.**

**SAVE THESE INSTRUCTIONS**

## IMPORTANT SAFETY INSTRUCTIONS (cont'd)

### CAUTION

- 1) USE ONLY RUWAC REPLACEMENT PARTS, ACCESSORIES AND HOSES SPECIFICALLY DESIGNED FOR YOUR MACHINE.
- 2) FOR SAFE USE SEE OPERATORS MANUAL
- 3) CLEAN UNIT DAILY
- 4) DO NOT USE WITH FLAMMABLE LIQUIDS, VAPORS OR ON SOLIDS CONTAMINATED WITH FLAMMABLE LIQUIDS.
- 5) DO NOT INSTALL WHERE THE MAXIMUM TEMPERATURE EXCEEDS THE IGNITION TEMPERATURE OF THE HAZARDOUS ATMOSPHERE(S)
- 6) TO PREVENT IGNITION OF HAZARDOUS ATMOSPHERES, DISCONNECT FROM THE POWER SUPPLY CIRCUIT BEFORE OPENING ENCLOSURE. KEEP TIGHTLY CLOSED WHILE CIRCUITS ARE LIVE.
- 7) DISCONNECT ELECTRICAL SUPPLY BEFORE SERVICING OR REPLACING FILTER.
- 8) TO REDUCE RISK OF ELECTRIC SHOCK DO NOT USE ON WET SURFACES. DO NOT EXPOSE TO RAIN. STORE INDOORS.
- 9) IF CONNECTED TO A CIRCUIT PROTECTED BY FUSES, USE TIME DELAY FUSES MARKED TYPE "D" WITH THIS APPLIANCE.
- 10) ANY MODIFICATIONS TO THIS UNIT VOIDS WARRANTY.

### AVERTISSEMENT

- 1) N'UTILISER QUE DES PIÈCES DÉTACHÉES ET ACCESSOIRES SPÉCIALEMEN CONÇUS POUR LA MARQUE RUWAC.
- 2) POUR VOTRE SÉCURITÉ, PRENEZ CONNAISSANCE DU MANUEL D'INSTRUCTION.
- 3) NETTOYEZ LA MACHINE JOURNELLEMENT.
- 4) NE PAS UTILISER PRÈS DES MATIÈRES INFLAMMABLES.
- 5) NE PAS UTILISER DANS DES LIEUX A ATMOSPHÈRES DANGEREUSE OÙ LA TEMPÉRATURE EST SUPÉRIEURE A LA TEMPÉRATURE D'IGNITION.
- 6) POUR ÉVITER L'IGNITION EN ATMOSPHÈRE DANGEREUSE, DÉBRANCHER LA PRISE ÉLECTRIQUE AVANT D'OUVRIR LE COUVERCLE. GARDER LE COUVERCLE FERMÉ LORSQUE LES CIRCUITS SONT SOUS TENSION.
- 7) DÉBRANCHER DE TOUTE SOURCE ÉLECTRIQUE AVANT TOUTE INTERVENTION OU REMPLACEMENT DU FILTRE.
- 8) POUR ÉVITER LES RISQUES D'ÉLECTROCUTION, NE PAS UTILISER EN ATMOSPHÈRE HUMIDE. NE PAS EXPOSER A LA PLUIE ET GARDER A L'INTÉRIEUR.
- 9) SI CONNECTÉ À UN CIRCUIT PROTÉGÉ PAR DES FUSIBLES, UTILISEZ DES FUSIBLES TEMPORISÉS DE TYPE « D » AVEC CET APPAREIL.
- 10) TOUTE INTERVENTION PAR UN TECHNICIEN NON QUALIFIÉ PAR RUWAC ANNULERA LA GARANTIE.
- 11) NE PAS APRIIR DE POUSSIERÈS INCANDESCENTERES NI D'AUTRAS SOURCES D'ALLUMAGE!

**SAVE THESE INSTRUCTIONS**

## IMPORTANT SAFETY INSTRUCTIONS (cont'd)

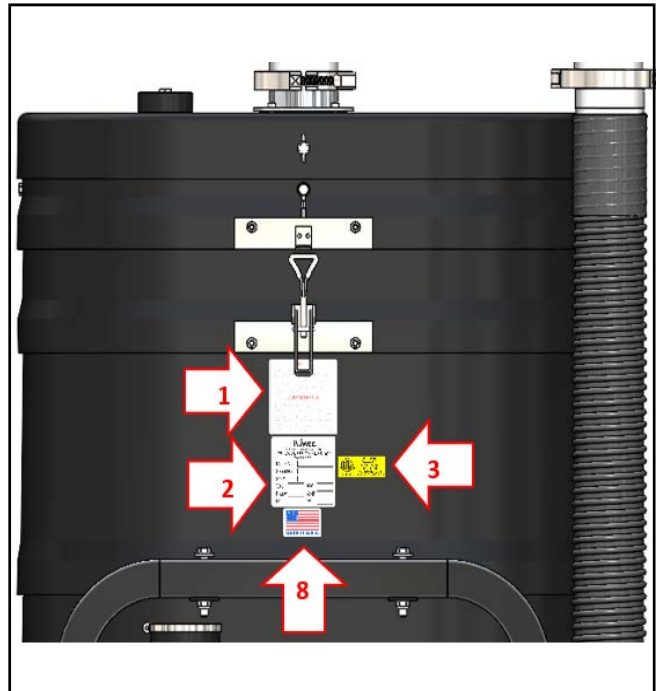
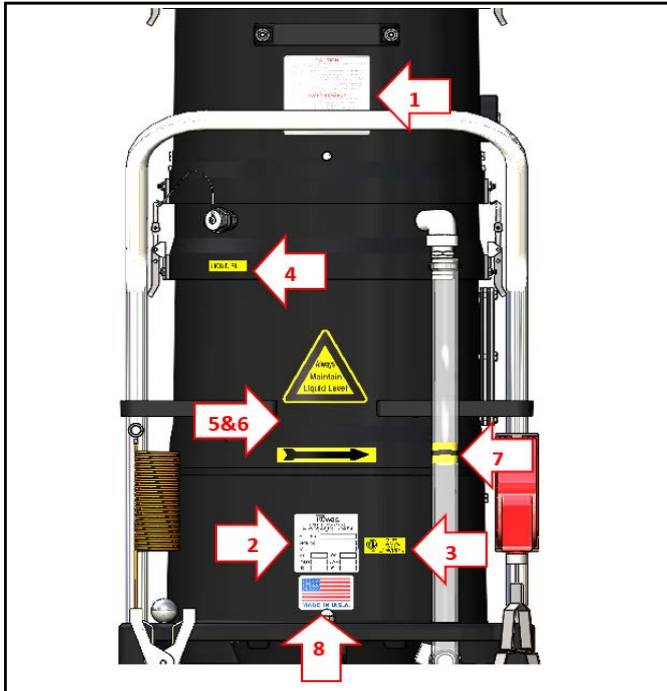

1. Caution Label
2. Serial Tag
3. UL Listing Label
4. Liquid Fill Label (attach hose here)
5. Liquid Level Warning Label
6. Water Level Indicator (Always verify liquid level through the sight glass, see Page 12, Step 2)
7. Water Level Indicator (Always verify liquid level through the sight glass, see Page 12, Step 2)
8. Made In the USA

**SAVE THESE INSTRUCTIONS**

## GROUNDING INSTRUCTIONS

This appliance must be grounded. If it should malfunction or breakdown, grounding provides a path of least resistance for electric current to reduce the risk of electric shock. This appliance is equipped with a cord having an equipment-grounding conductor and grounding plug. The plug must be inserted into an appropriate outlet that is properly installed and grounded in accordance with all local codes and ordinances.

**DANGER:** Improper connection of the equipment-grounding conductor can result in a risk of electric shock. The conductor with insulation having an outer surface that is green with or without yellow stripes is the equipment-grounding conductor. If repair or replacement of the cord or plug is necessary, do not connect the equipment-grounding conductor to a live terminal. Check with a qualified electrician or serviceman if the grounding instructions are not completely understood, or if in doubt as to whether the appliance is properly grounded. Do not modify the plug provided with the appliance -- If it will not fit the outlet, have a proper outlet installed by a qualified electrician.

This appliance is for use on a circuit having a nominal rating more than 115 V and is factory-equipped with a specific electric cord and plug to permit connection to a proper electric circuit. Make sure that the appliance is connection to an outlet having the same configuration as the plug. No adaptor should be used with this appliance. If the appliance must be reconnected for use on a different type of electric circuit, the reconnection should be made by qualified service personnel; And after the reconnection, the appliance should comply with all local codes and ordinances.

## GROUNDING INSTRUCTIONS

### ABOUT RUWAC'S MX300 / MX300EX / MX360 / MX360EX UNITS AND GROUND:

- ALL MX300 / MX300EX / MX360 / MX360EX UNITS ARE CONSTRUCTED OF COMPRESSION CAST COMPOSITE HOUSING TO ENSURE THEY ARE FULLY GROUNDED AND STATIC DISSIPATING DURING OPERATION
- ALL METAL COMPONENTS ARE GROUNDED VIA A SERIES OF INTERNAL GROUND WIRES
- A STANDARD OHMMETER CAN CONFIRM PROPER GROUND. SEE PICTURES BELOW

## GROUNDING

The following is a list of items that should periodically be checked for continuity. Please note that while all clamps are grounded, they should still be tested in relation to each other and other parts.

### For MX300

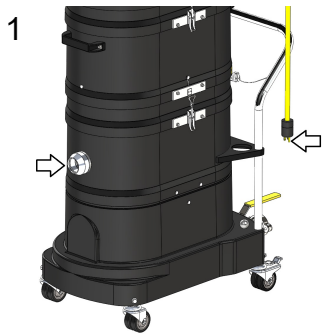

1 Power cord line ground to inlet.

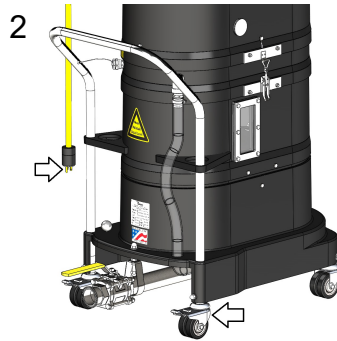

2 Power cord line ground to all four casters.

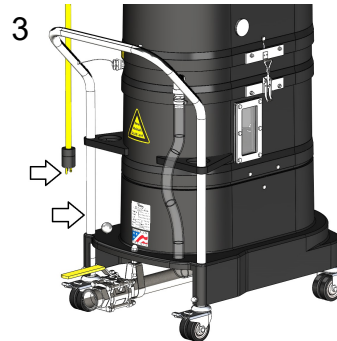

3 Power cord line ground to handlebar.

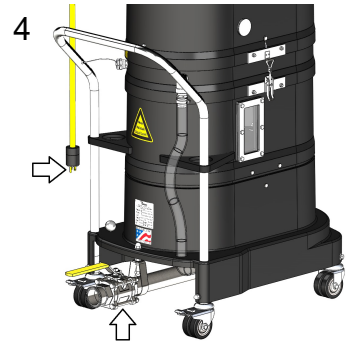

4 Power cord line ground to ball valve (**Note:** Do not ground to ball valve handle as continuity is inconsistent.)

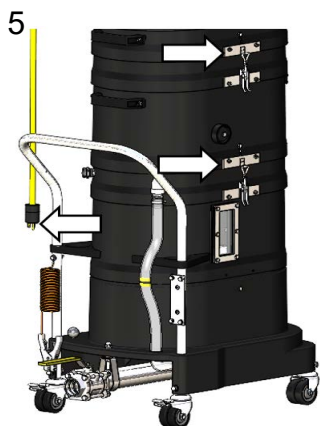

5 Power cord line ground to all housing clamps.



6 Power cord line ground to grounding cable hand clamp.



7 Power cord line ground to garden hose fit.

## GROUNDING INSTRUCTIONS

### GROUNDING

The following is a list of items that should periodically be checked for continuity. Please note that while all clamps are grounded, they should still be tested in relation to each other and other parts.

#### For MX360

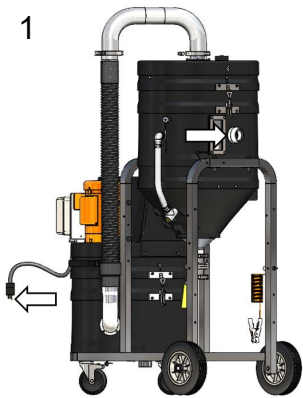

1 Power cord line ground to inlet.

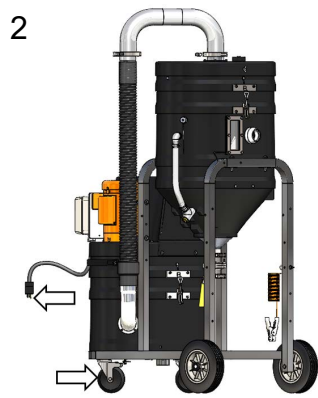

2 Power cord line ground to all four casters.

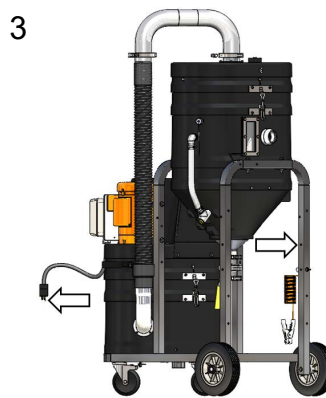

3 Power cord line ground to handlebar.

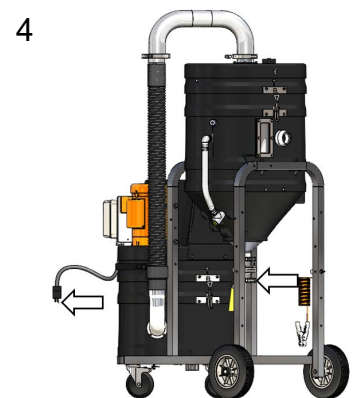

4 Power cord line ground to ball valve (**Note:** Do not ground to ball valve handle as continuity is inconsistent).

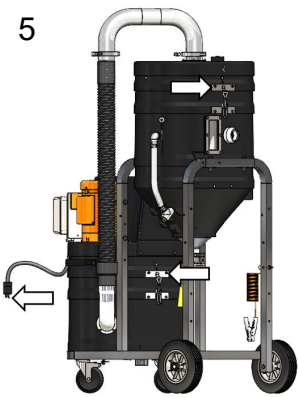

5 Power cord line ground to all housing clamps.

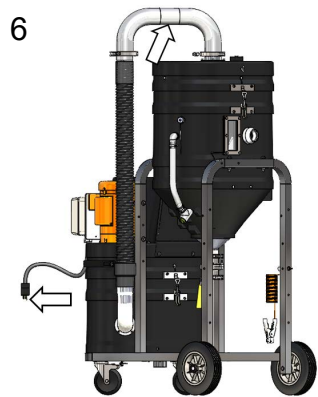

6 Power cord line ground to sanitary elbow.

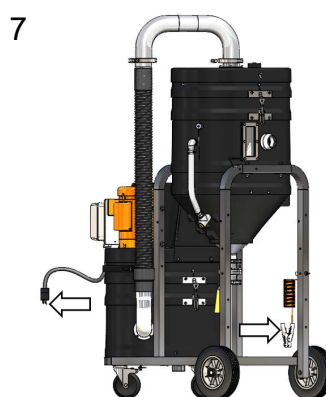

7 Power cord line ground to grounding cable hand clamp.

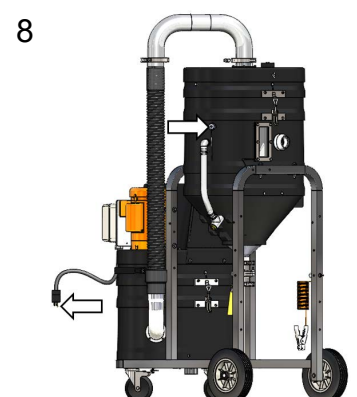

8 Power cord line ground to garden hose fit.



---

## GROUNDING INSTRUCTIONS

- \* Air powered models do not have line ground, so check the end of the ground cable where instructions state "line ground."
- \*\* To check continuity of any carbon impregnated components, only a Megohm meter shall be used should measure less than 1 mΩ.
- \*\*\* To check the continuity of a vacuum hose, turn the multi meter to an ohm reading. Touch each end of the ohm meter to the grounds on the end of the hose. The noise on the ohm meter signifies continuity. To check the continuity of the complete vacuum system, connect one end of the hose to the machine (vacuum's inlet) and then touch one end of the ohm meter to the ground on the power cable and the other end of the ohm meter to the ground of the hose. The noise on the ohm meter signifies continuity.

## BONDING

Two machines that are independently bonded may not have the same electrical potential (resistance). It has been documented that even though the machines are independently grounded, a static discharge can travel from one ground machine to another. In order to ensure that all equipment has the same potential and is equally grounded, your application may require that the machines be bonded together. The MX300 / MX360 / MX360EX's retractable grounding cable installed on the handle bar will provide this extra source of bonding.

Note: Make sure you include the handle bar in your daily continuity testing if using it to bond equipment. Air powered vacuums that are bonded would have two (2) retractable grounding reels: One for grounding and one for bonding.

**Only Ruwac explosion proof accessories should be used with your MX300 / MX300EX / MX360 / MX360EX unit. Using any other accessories will compromise the safety of your machine, potentially rendering creating a dangerous environment.**

**MX300 / MX300EX / MX360 / MX360EX SERIES INSTRUCTIONS:  
START-UP OPERATION**

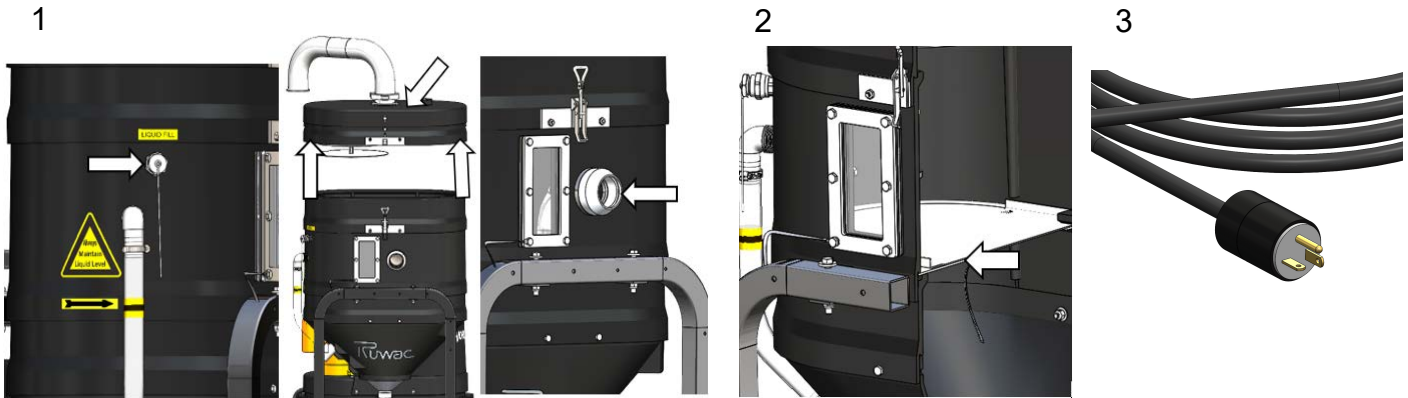

1  
Fill unit with liquid to indicated level. Unit may be filled using garden hose connection, or by removing lid from immersion tank, or by pouring in liquid directly using the inlet connection.

2  
Ensure liquid level is not above the dispersion screen. (Note: Housing cutaway shown for clarity).

3  
Connect machine to appropriate power source as indicated on serial tag.

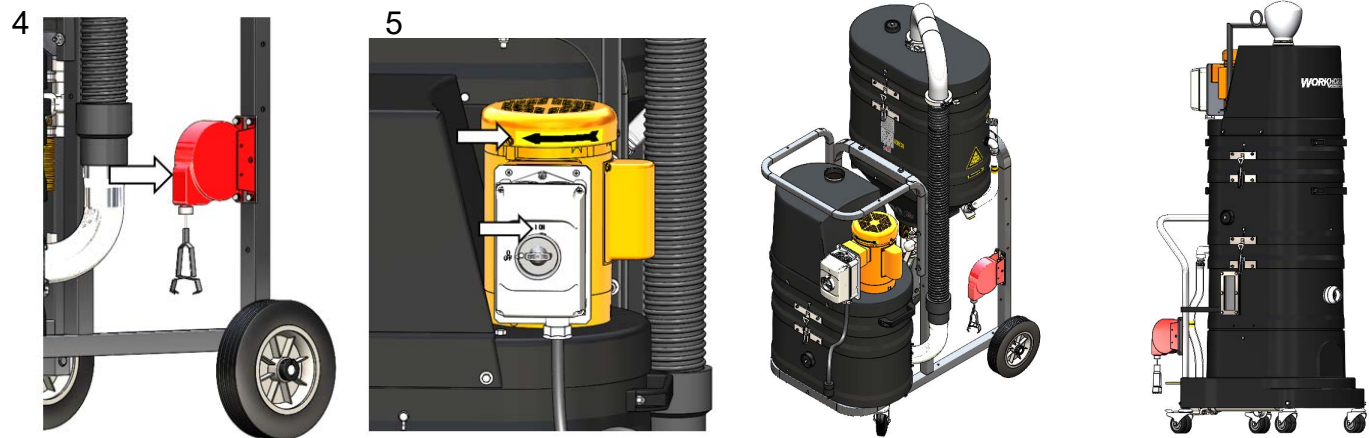

4  
Affix retractable grounding cable (optional) to an adequately grounded structure.

5  
“Bump” the motor by quickly pressing start then stop. Check that the motor is spinning in the indicated direction (CLOCKWISE).

6  
If motor is spinning properly, the unit is ready for operation.

**CAUTION:** Always check that the motor is rotating in the indicated direction upon start-up. Power polarity can change from power supply to power supply. Operation under a reversed polarity will damage the motor, the turbine and / or the machine.

### MX300 / MX300EX / MX360 / MX360EX SERIES INSTRUCTIONS: STANDARD SERIES FILTER BAG INSTALLATION AND BALL VALVE DISCHARGE

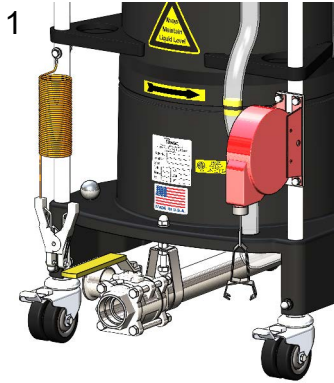

For best performance, drain unit daily using the valve.

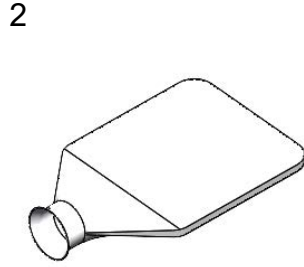

If desired, an after filter may be used to separate solids from immersion fluid.

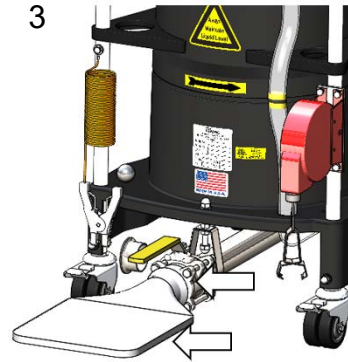

Place the filter bag over the sanitary fitting and secure with the sanitary clamp.



Drain unit into filter bag. Be sure to rinse filter bag after use.

**Note:** Do not store unit with waste material and / or liquid inside.

### FILTER HOUSING DRAIN

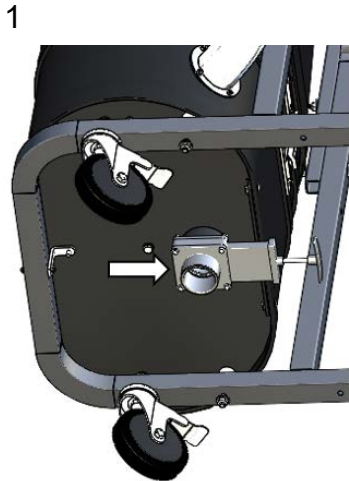

Liquid may collect in the filter housing. It is important that you drain this section completely by opening the gate valve on the bottom plate. Make sure that the gate is closed when finished.

**MX300 / MX300EX / MX360 / MX360EX SERIES INSTRUCTIONS:  
MX360 SERIES LEVEL INDICATOR CLEANING  
(ONLY FOR MACHINES PURCHASED AFTER 6/1/19)**

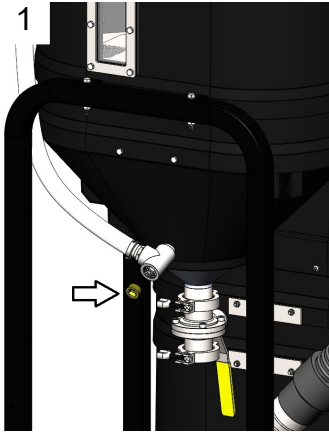

Unscrew PVC plug #27934.

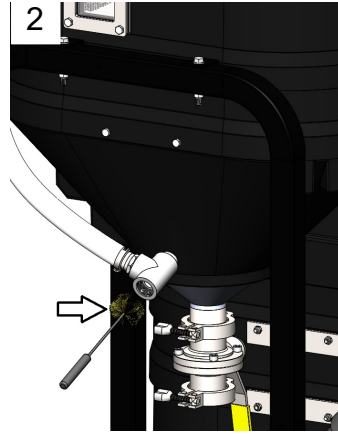

Take a brush and insert into PVC tee #316561PVC. Rotate brush to agitate settled material inside tee.

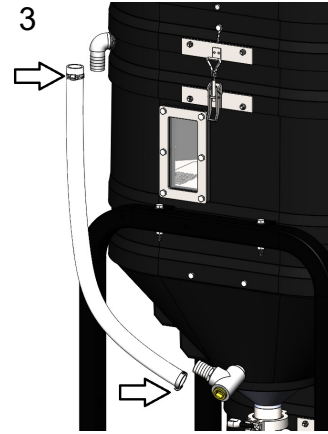

Reinstall PVC plug.

**LEVEL INDICATOR HOSE REPLACEMENT**

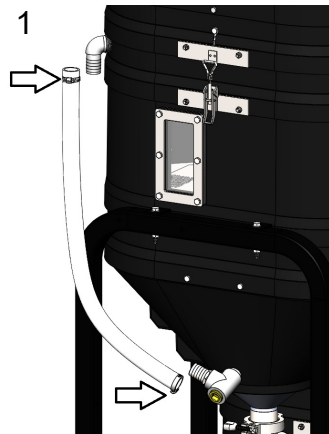

Loosen both hose clamps #4026 and remove hose #MA4340A03

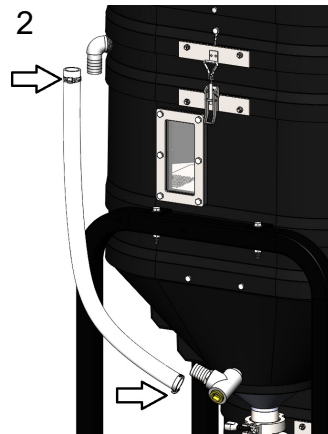

Replace hose and re-attach hose clamps.

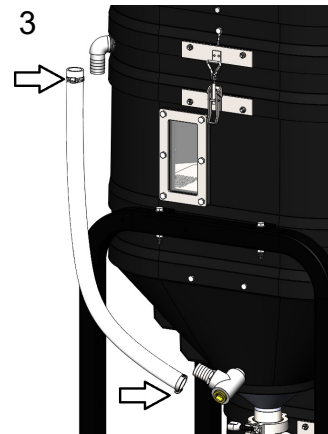

Reattach each end of hose to PVC hose barb #27890PVC and hose barb #316411PVC.

**MX300 / MX300EX / MX360 / MX360EX SERIES INSTRUCTIONS:  
MX360 SERIES FILTER BAG INSTALLATION AND BALL / BUTTERFLY VALVE  
DISCHARGE**



For best performance, drain unit daily using the valve.

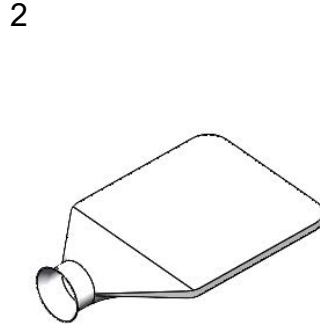

If desired, an after filter may be used to separate solids from immersion fluid.

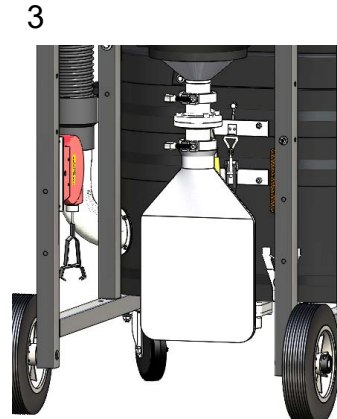

Place the filter bag over the sanitary fitting. Use sanitary clamp to secure filter.



Drain unit into filter bag. Be sure to rinse filter bag after use. **(Note: Use a bucket under the filter bag when draining).**

**MX300 / MX300EX / MX360 / MX360EX SERIES INSTRUCTIONS:  
STANDARD SERIES CARTRIDGE FILTER & DEMISTING PAD CLEANING**

1. The standard MX300 / MX300EX should be cleaned after each use to avoid off-gassing.
2. The demisting screen and the filters should be checked on a weekly basis to ensure efficiency.
3. The demisting chamber and filters should be checked for excessive sediment build-up on a regular basis.  
Empty and flush out the unit to ensure there is no build up of material above the liquid bath. Clean the unit thoroughly.
4. The sight glass window must be free from debris and offer visibility into the vacuum. Replace as required.



Turn machine off and disconnect from power supply.



Release the clamps and remove motordeck from filter housing.



Loosen filter hold-down tabs, and remove cartridge filters.

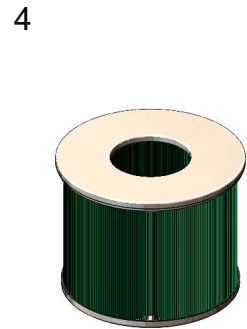

Inspect filters for damage or excessive material blockage. Clean filters per instructions in Appendix A.

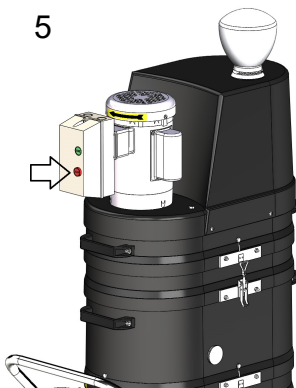

Release the clamps and remove the demisting assembly from the immersion tank.

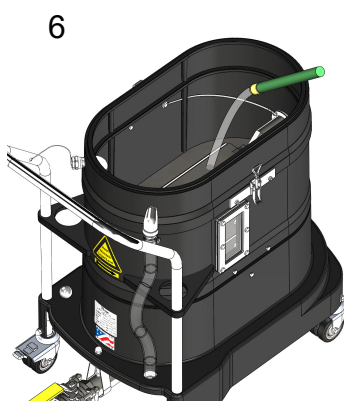

Clean the dispersion screen by rinsing thoroughly with water.

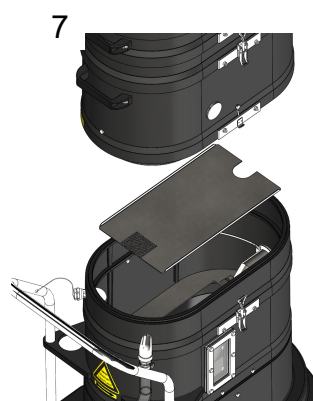

Remove the dispersion screen.



With dispersion screen removed, rinse immersion tank to remove any remaining material. Open ball valve to allow water to drain.

**CAUTION:** Motor deck will be heavy and will require a crane to place atop work bench or table.

**MX300 / MX300EX / MX360 / MX360EX SERIES INSTRUCTIONS:  
STANDARD SERIES CARTRIDGE FILTER & DEMISTING PAD CLEANING**

9

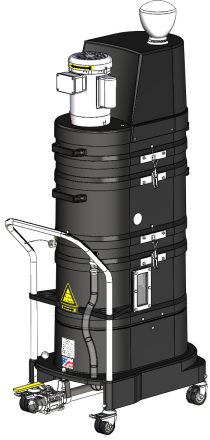

**After cleaning  
the machine,  
reassemble all  
components. Be sure  
to secure all clamps  
to ensure machine is  
properly grounded.**

Use a cloth rag to remove excess water from rinsing. Take extra care to make sure demisting pad is dry. Excess water in the demisting pad may reduce filter efficiency over time.



## **ALSO AVAILABLE: DUST EXTRACTION SWING ARM**

**SAFELY REMOVES AIRBORNE DUSTS, GASES AND SMOKE  
EMITTED DURING THE MANUFACTURING PROCESS**

The Dust Extraction Swing Arm are fully mobile and retractable mounted onto a pivot arm extension. It also features a spring-loaded arm with an adjustable tensioner guarantees positive placement once fixed into the position of your choosing.

- Fully mobile
- Retractable reach
- 360° Swivel
- Fully rotational 3" capture hood
- Compact design
- Adaptable to any of the following Ruwac vacuum series:  
AV, AV-EX, DS1, DS2, DS2-EX, FRV, WNS, WS,  
MX300 / MX300EX MX360 / MX360EX





**MX300 / MX300EX / MX360 / MX360EX SERIES INSTRUCTIONS:  
MX360 / MX360EX SERIES CARTRIDGE FILTER & DEMISTING PAD CLEANING**

1. The MX360 / MX360EX should be cleaned after each use to avoid off-gassing.
2. The demisting screen and the filters should be checked on a weekly basis to ensure efficiency.
3. The demisting chamber and filters should be checked for excessive sediment build-up on a regular basis.  
Empty and take apart the unit to ensure there is no build up of material above the liquid bath. Clean the unit thoroughly.
4. The sight glass window must be free from debris and offer visibility into the vacuum. Replace as required.



1 Turn machine off and disconnect from power supply.

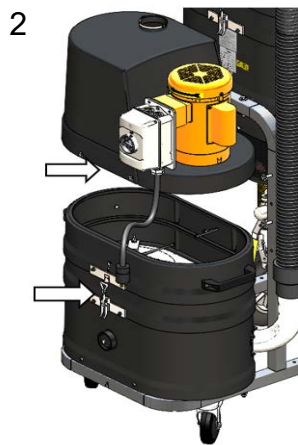

2 Release the clamps and remove motor deck from filter housing.

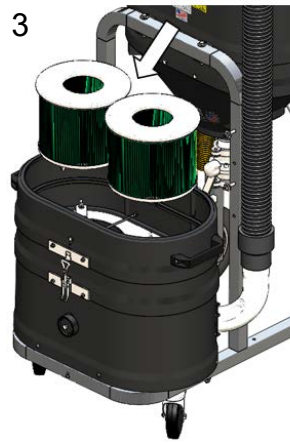

3 Loosen filter hold-down tabs, and remove cartridge filters.

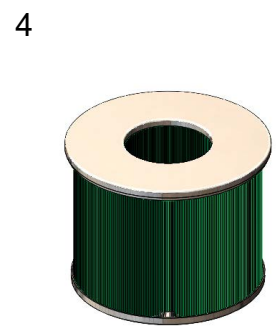

4 Inspect filters for damage or excessive material blockage. Clean filters per instructions in Appendix A.



5 Release the sanitary clamp of the connection hose and elbow and remove the sanitary elbow.



6 Remove the lid by unscrewing its hardware. Backwash the demisting pad by rinsing thoroughly with water.

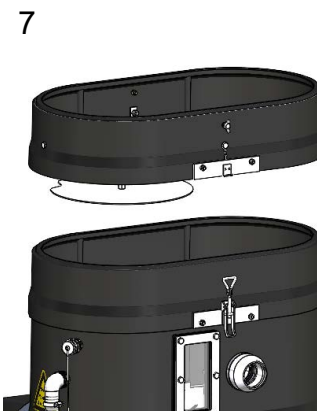

7 Release the clamps and remove the demisting assembly from the immersion tank.



8 Clean the dispersion screen by rinsing thoroughly with water.

**CAUTION:** Motor deck will be heavy and will require a crane to place atop work bench or table.

**MX300 / MX300EX / MX360 / MX360EX SERIES INSTRUCTIONS:  
MX360 / MX360EX SERIES CARTRIDGE FILTER & DEMISTING PAD CLEANING**



9  
Remove the dispersion screen.



10  
Rinse immersion tank to remove any remaining material. Place a bucket underneath, and open the valve to allow water to drain.



11  
Use a cloth rag to remove excess water from rinsing. Take extra care to make sure demisting pad is dry. Excess water in the demisting pad may reduce filter efficiency over time. The demisting pad will self-drain if clean.

**After drying machine, reassemble all components. Be sure to secure all clamps to ensure machine is properly grounded.**

**NOTE:** Not all of the liquid water will drain out of the unit via the discharge hose. Prepare the work area accordingly.

## IV. \_\_\_\_\_ Inspection & Maintenance

### MX300 / MX300EX / MX360 / MX360EX SERIES INSTRUCTIONS: TURBINE REPLACEMENT

**NOTE:** The turbine is not field serviceable and must be replaced as one unit if defective. Replacement of the motor belt or turbine will require the turbine seal to be replaced.

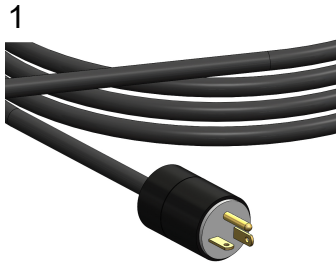

Switch the vacuum off and remove the power cord from the power source.



Remove the vacuum from the hazardous area to a service work area where the motor deck can be rested on a work bench or table.



Remove the silencer assembly from the motor deck.

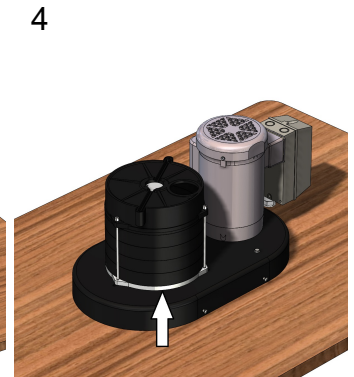

Break the silicone seal surrounding the turbine using a sharp edge.

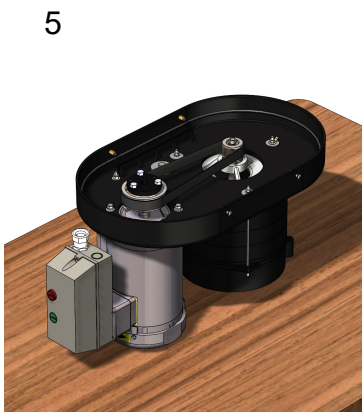

Carefully turn motor deck upside down onto work bench or table.



Remove belt by walking it off.

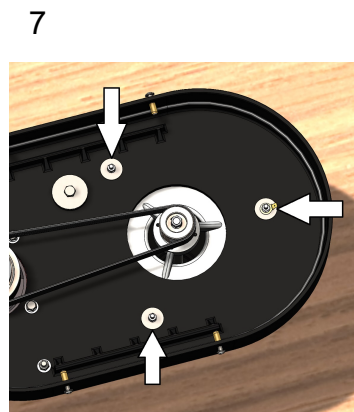

Loosen the three nuts securing the turbine, supporting it from underneath to ensure it doesn't drop.

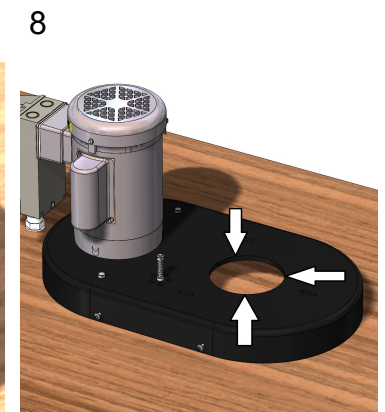

Using a sharp edge, remove the remaining silicone seal from the motor deck.

**CAUTION:** Motor deck will be heavy and will require a crane to place atop work bench or table.

**MX300 / MX300EX / MX360 / MX360EX SERIES INSTRUCTIONS:  
TURBINE REPLACEMENT**

9

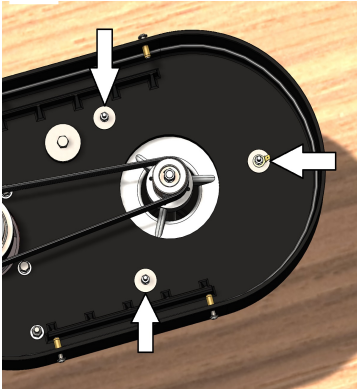

Replace the turbine by fastening all nuts and bolts through bottom of motor deck.

10

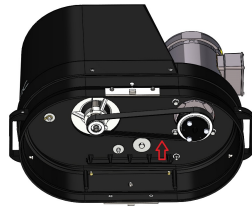

Align and install new motor belt (See pgs.23 & 24 for instructions).

11

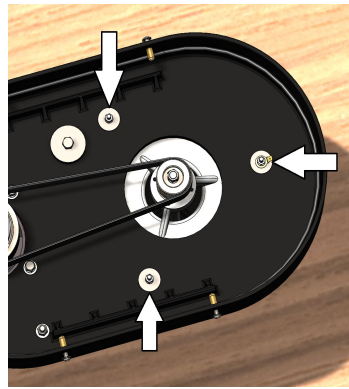

Tighten all nuts and bolts surrounding the turbine to ensure they're fastened securely. Do not over tighten.

12



Flip fully assembled motor deck upright, resting front end on a support so as not to move underlying bushing and belt.

13

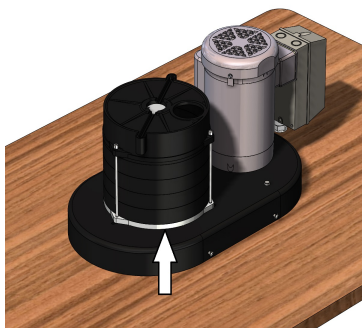

Reapply silicone, and let sit it for 2 hours or until dry (not tacky).

**CAUTION:** Motor deck will be heavy and will require a crane to place atop work bench or table.



**MX300 / MX300EX / MX360 / MX360EX SERIES INSTRUCTIONS:  
BELT INSPECTION**

**CAUTION: Motor deck will be heavy and will require a hoist to remove.** Before any maintenance service is done, follow standard lock out and tag out procedures as well.

1

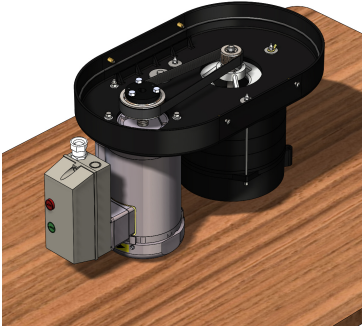

With power disconnected, remove the motor deck. Place the motor deck upside-down on a clean working surface.

2

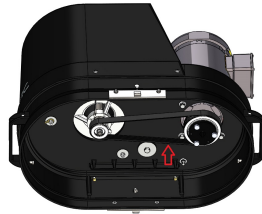

Inspect the belts for any glazing, cracking or shredding. Any of these will require belt replacement (See below for belt replacement instructions).

3

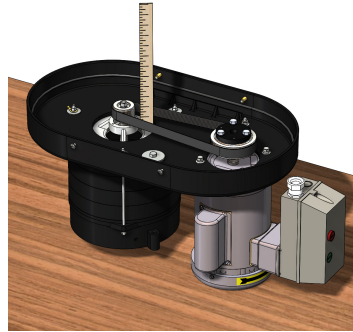

Check that sheaves are properly aligned (See pg. 25 for pulley alignment instructions).

4

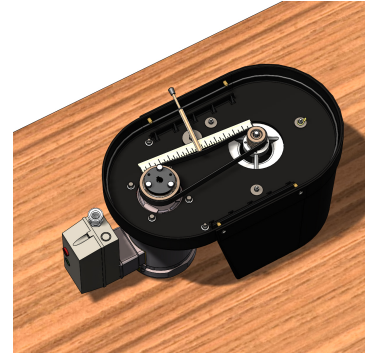

Check tension using a straight edge and tension gauge as shown above. (See pg. 24 for belt tensioning instructions).

**REPLACING THE BELT**

1

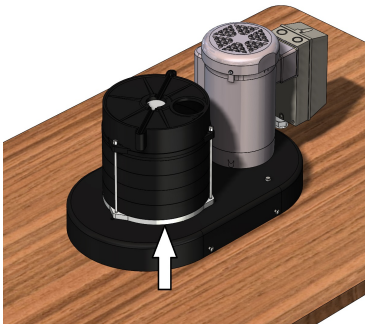

To replace a drive belt, first cut and remove silicone around the turbine.

2

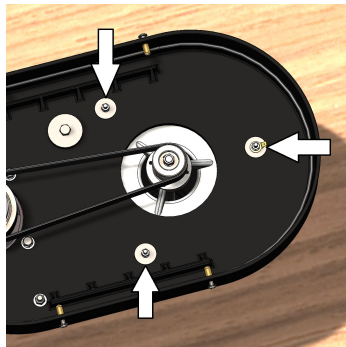

Loosen the turbine hardware, then slide the turbine towards the motor to loosen the belt.

3

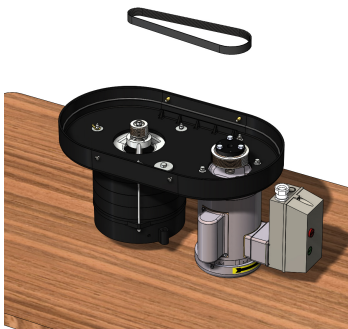

Remove old belt and replace with a new one.

4



Properly tension belt by following belt tensioning instructions on pg. 24.

**MX300 / MX300EX / MX360 / MX360EX SERIES INSTRUCTIONS:  
BELT TENSIONING**

**CAUTION: Motor deck will be heavy and will require a hoist to remove.** Before any maintenance service is done, follow standard lock out and tag out procedures as well.

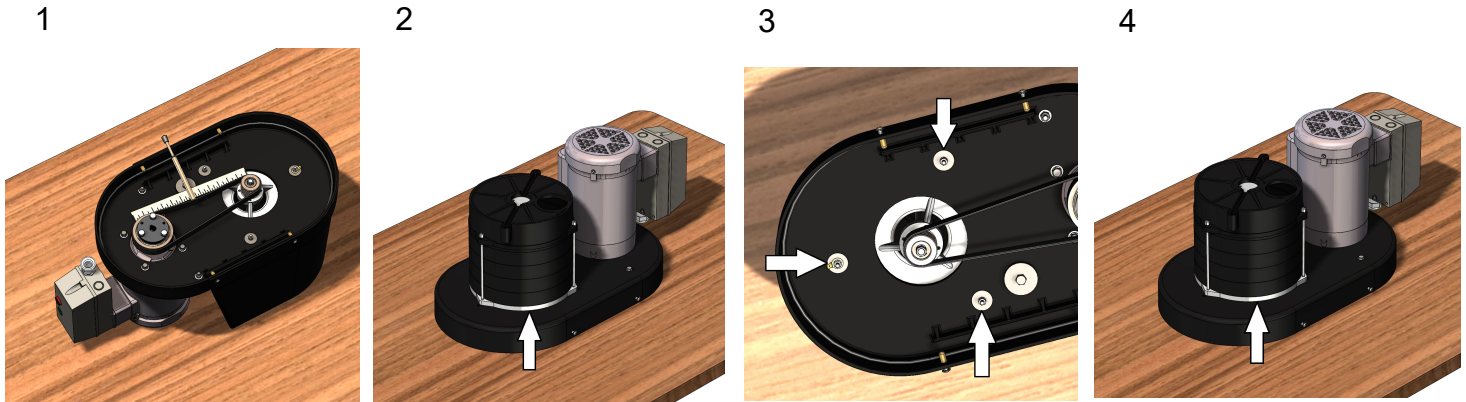

1 Measure belt tension by using a straight edge and tension gauge as shown above. Refer to diagram below for proper tension specifications.

2 To tighten belt, slide turbine away from the motor. Before sliding the turbine, the silicone on the top of the motordeck must be cut and removed.

3 After removing the silicone, loosen the turbine hardware and adjust the turbine position as necessary.

4 Once the belt has been properly tensioned, secure the hardware and re-seal the turbine with silicone.

New 6-groove belts should be set to 6lbs at 3/16" of deflection. New 10-groove belts should be set to 9lbs at 3/16" of deflection. Allow new belts to stretch by running in for several hours. After run-in period, 6-groove belts should be between 4lbs to 5lbs, and 10-groove belts should be between 7lbs to 8lbs.

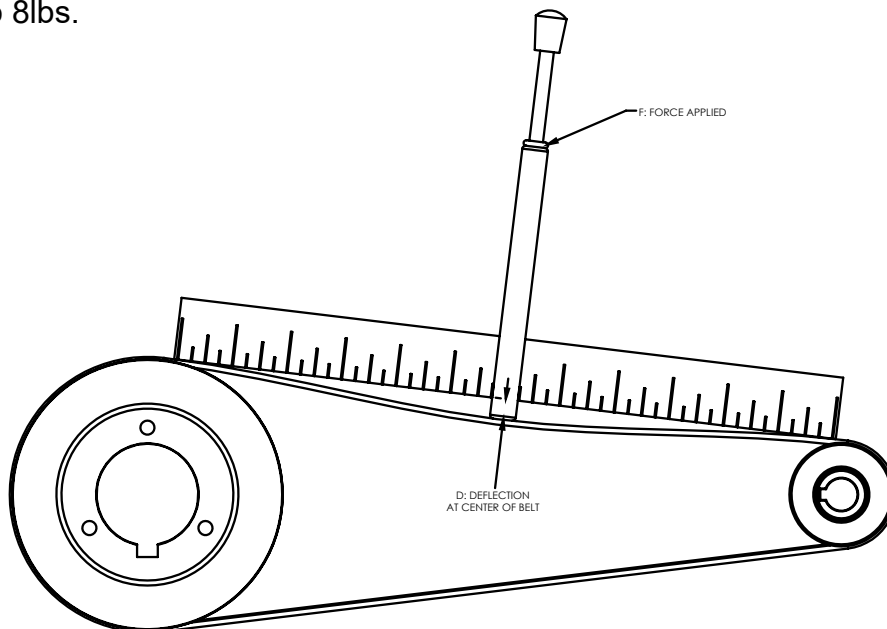

## IV. \_\_\_\_\_ Inspection & Maintenance

### MX300 / MX300EX / MX360 / MX360EX SERIES INSTRUCTIONS: PULLEY ALIGNMENT

**NOTE:** Complete the previous operations to prepare the motor deck for service of the motor, turbine or belt. Replace any defective components and secure the motor with bolts before proceeding.

1

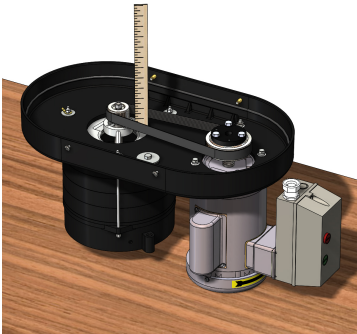

Measure the height of the first groove on the turbine sheave. Check that the first groove of the motor sheave matches this height.

2

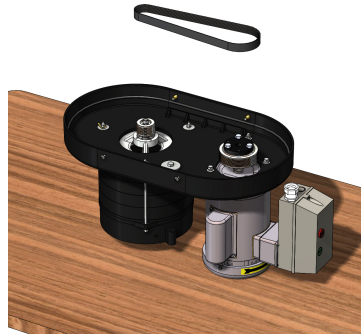

If motor sheave needs adjustment, remove belt and adjust motor sheave (See pg. 23 for belt removal instructions).

3

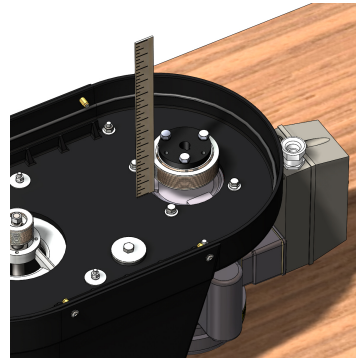

Loosen motor sheave hardware, and slide up or down as necessary.

4

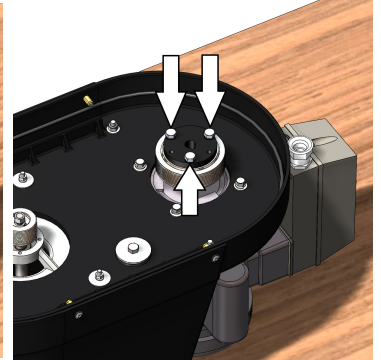

Once motor sheave is at correct height, tighten bolts to 15 ft-lbs. of torque.

5

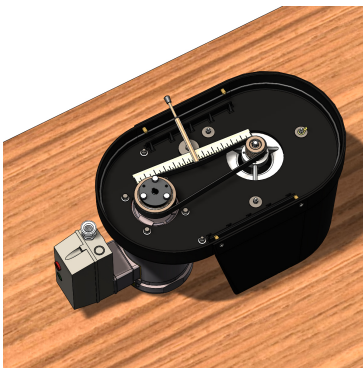

Re-install the belt and adjust to proper tension (See pgs. 23 and 24).



## **ALSO AVAILABLE: EXPLOSION PROOF VACUUMS**

Ruwac recognizes the seriousness of the potential deadly hazard found in dry combustible dust, and offers a complete line of explosion proof vacuum systems available in:

- ETL Certified to UL and CSA standards for Class I, Div 1, 2, Group D and Class II, Div 1, 2, Group F & G
- Class II, Division 2 compliant to NFPA 652 and 654's minimum requirements as permitted to be used to collect hazardous dusts in unclassified areas
- Air-powered explosion proof vacuums self-certified to UL, CSA and ATEX standards that apply for electric machines
- Custom central vacuum systems





**MX300 / MX300EX / MX360 / MX360EX SERIES INSTRUCTIONS:  
AIR-POWERED DECK INSPECTION**

**NOTE:** For air-powered units with 70 PSI at 65 CFM, you ***MUST*** use a 1/2" NPT unrestricted air line.

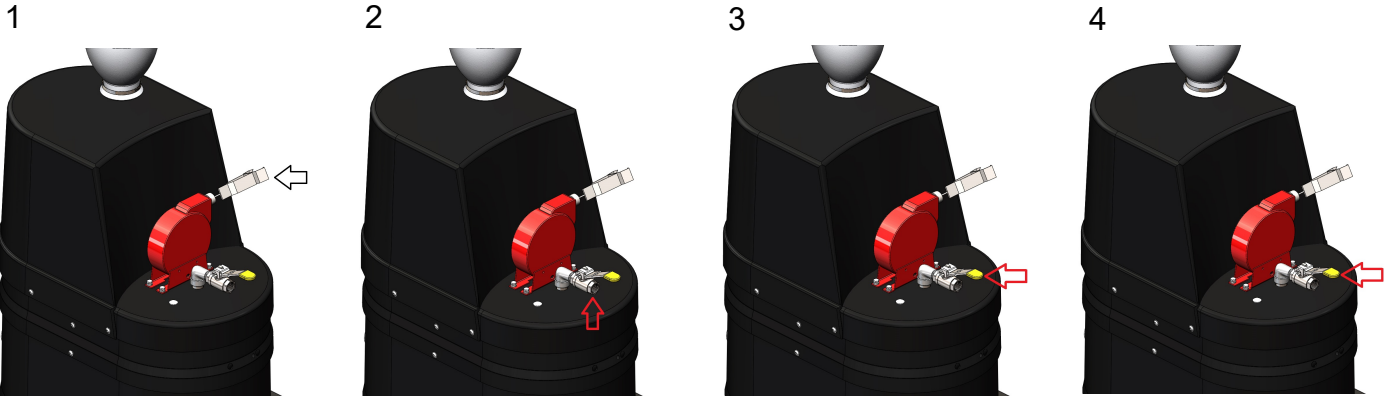

Affix the retractable grounding cable to an adequately grounded structure or object.

Attach full port air supply connection. A 1/2" unrestricted air line is absolutely required for optimal operation.

Open the ball valve to turn the vacuum on by pulling the lever toward you.

Close the ball valve to turn the vacuum off by pushing the lever away from you.

**ELECTRIC MOTOR DECK INSPECTION**

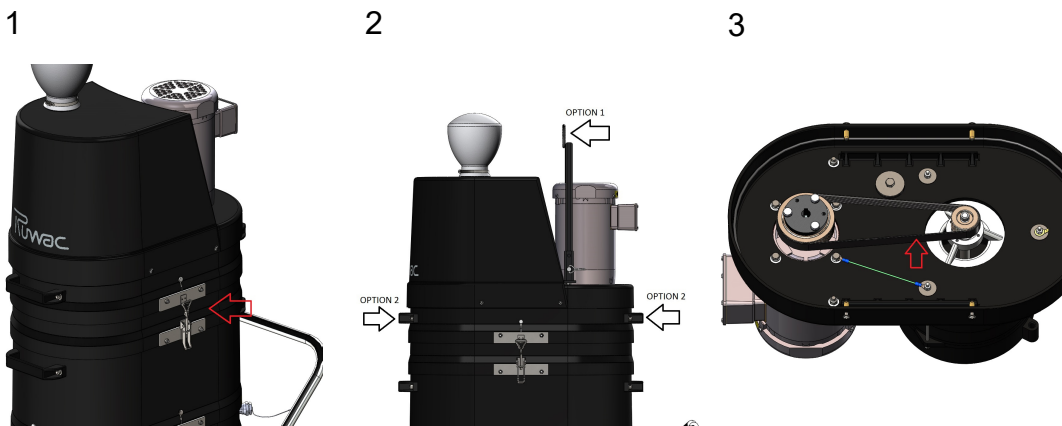

Unlatch the housing clamps on both sides of the MX300 / MX300EX unit.

Using either a manual lift or with two people using the handles, lift the motor deck up from the MX300 / MX300EX unit.

Either from the lift or by turning the motor deck over on a table, inspect the belt for cracks, wear, melt, stretch and tension (Make sure to support the motor and turbine equal-ly). If damaged, see Belt Replacement and / or Belt Tensioning instructions (Pages 24 & 25).

**INSPECTION & MAINTENANCE OF MX300 / MX360 SERIES ELECTRICAL GROUNDING**

To operate safely, the MX300 / MX300EX / MX360 / MX360EX immersion separator must be properly grounded. The grounding system of the unit can be tested by checking for electrical continuity as shown below. Grounding should be checked weekly or after the machine has been taken apart for any maintenance. If continuity is not found at any of the locations shown below, all the grounding wires and terminals should be inspected. The location of all the ground wires can be found in the diagrams starting on pg.33.

**For MX300**

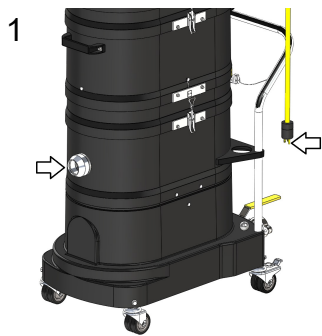

1 Power cord line ground to inlet.

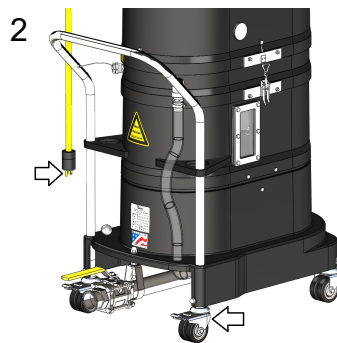

2 Power cord line ground to all four casters.

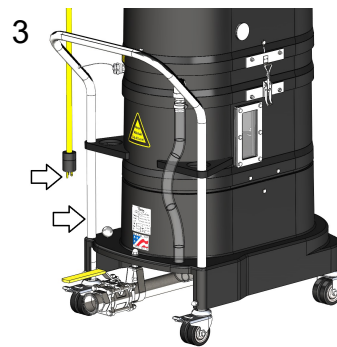

3 Power cord line ground to handlebar.

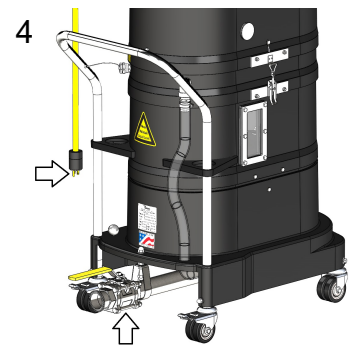

4 Power cord line ground to ball valve (**Note:** Do not ground to ball valve handle as continuity is inconsistent.)

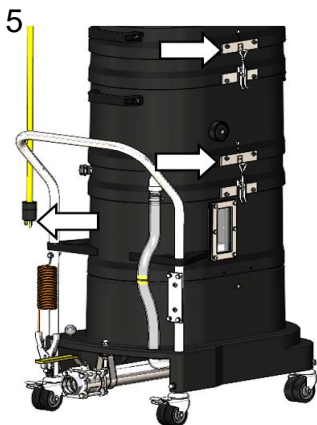

5 Power cord line ground to all housing clamps.



6 Power cord line ground to grounding cable hand clamp.



7 Power cord line ground to garden hose fit.

**INSPECTION & MAINTENANCE OF MX300 / MX360 SERIES ELECTRICAL GROUNDING**

To operate safely, the MX300 / MX300EX / MX360 / MX360EX immersion separator must be properly grounded. The grounding system of the unit can be tested by checking for electrical continuity as shown below. Grounding should be checked weekly or after the machine has been taken apart for any maintenance. If continuity is not found at any of the locations shown below, all the grounding wires and terminals should be inspected. The location of all the ground wires can be found in the diagrams starting on pg.33.

**For MX360**

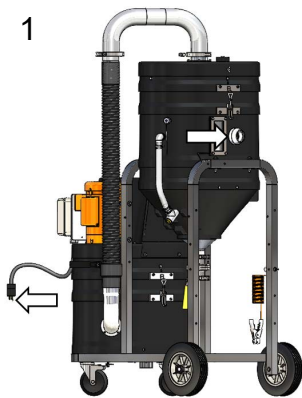

1 Power cord line ground to inlet.

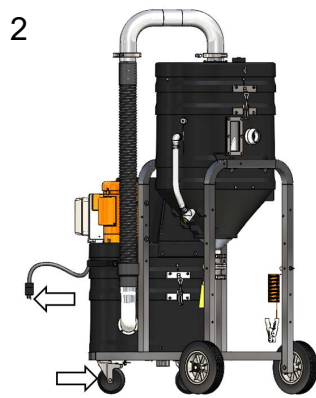

2 Power cord line ground to all four casters.

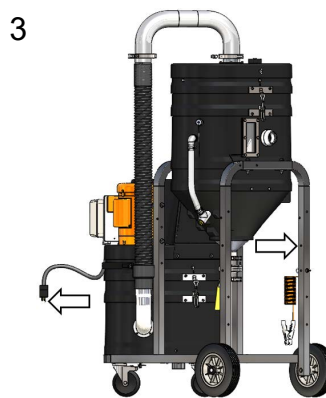

3 Power cord line ground to handlebar.

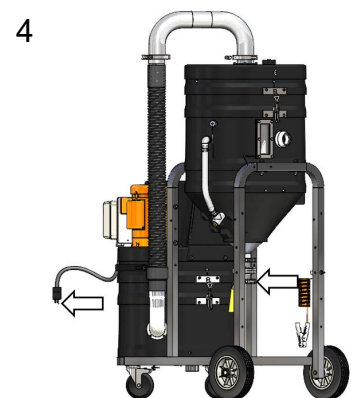

4 Power cord line ground to ball valve (**Note:** Do not ground to ball valve handle as continuity is inconsistent).

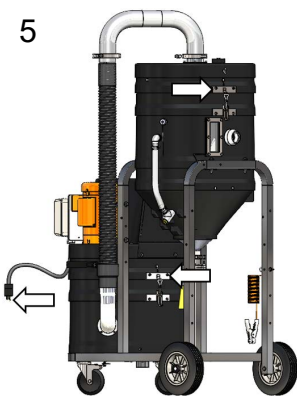

5 Power cord line ground to all housing clamps.

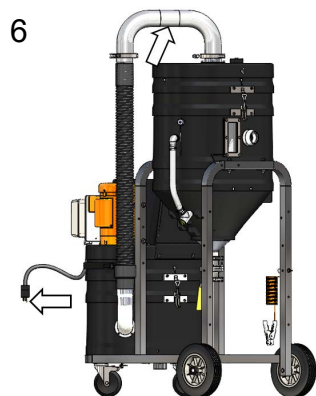

6 Power cord line ground to sanitary elbow.

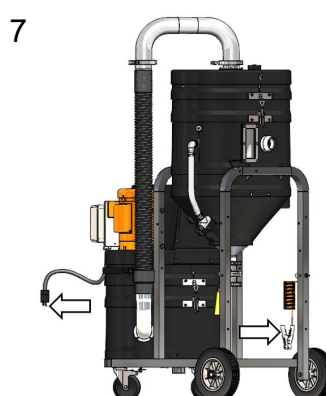

7 Power cord line ground to grounding cable hand clamp.

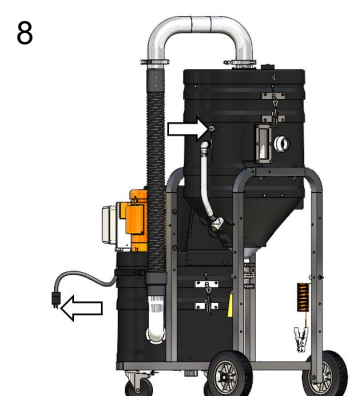

8 Power cord line ground to garden hose fit.

## INSPECTION & MAINTENANCE OF MX300 / MX360 SERIES ELECTRICAL GROUNDING

\* Air powered models do not have line ground, so check the end of the ground cable where instructions state "line ground."

\*\* To check continuity of any carbon impregnated components, only a Megohm meter shall be used should measure less than 1 mΩ.

\*\*\* To check the continuity of a vacuum hose, turn the multi meter to an ohm reading. Touch each end of the ohm meter to the grounds on the end of the hose. The noise on the ohm meter signifies continuity. To check the continuity of the complete vacuum system, connect one end of the hose to the machine (vacuum's inlet) and then touch one end of the ohm meter to the ground on the power cable and the other end of the ohm meter to the ground of the hose. The noise on the ohm meter signifies continuity.

When checking ground wires, make sure that the terminals at both ends are properly secured. There are two types of terminals used on this unit:

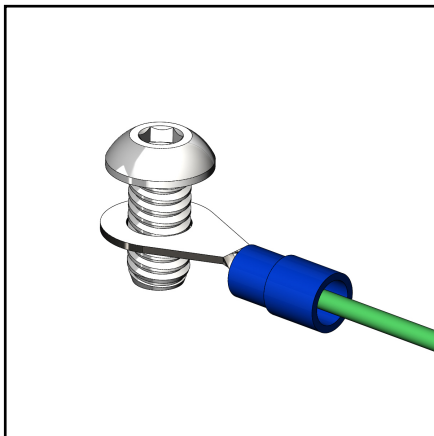

**Ring Terminals:** Check that the ring terminal is crimped securely to the end of the wire. Check that the terminal is free from corrosion. Ring terminals can corrode if exposed to excessive moisture.

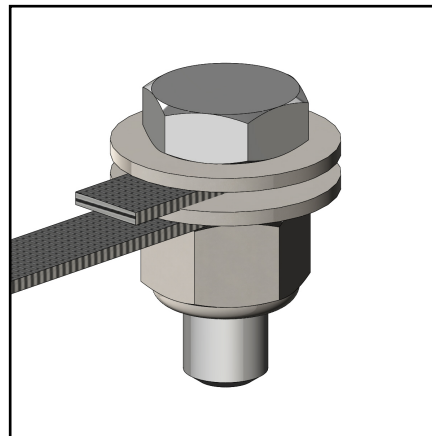

**Stainless Wire and Washers:** Stainless wire and washers are used in areas exposed to moisture to avoid corrosion. Check that the braided wire is properly looped through the washers as show above.

## INSPECTION & MAINTENANCE OF MX300 / MX300EX / MX360 / MX360EX SERIES ELECTRICAL GROUNDING

1. Drain unit completely and clean it thoroughly.
2. Check that the ground wire terminals are securely fastened and free from excessive corrosion. (See Figures 1, 2 for all filter and base ground wires and terminal numbers.)

**(MX300 / MX300EX ONLY)  
IMMERSION BASE - 7 WIRES**

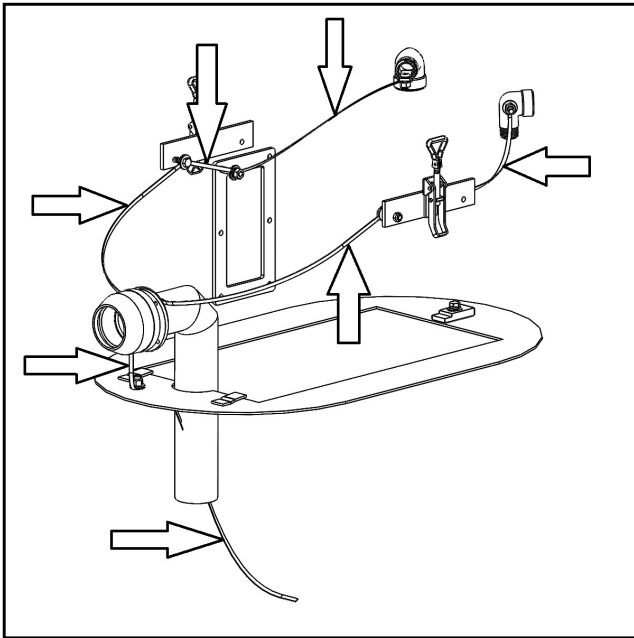

**CASTERS - 4 WIRES**

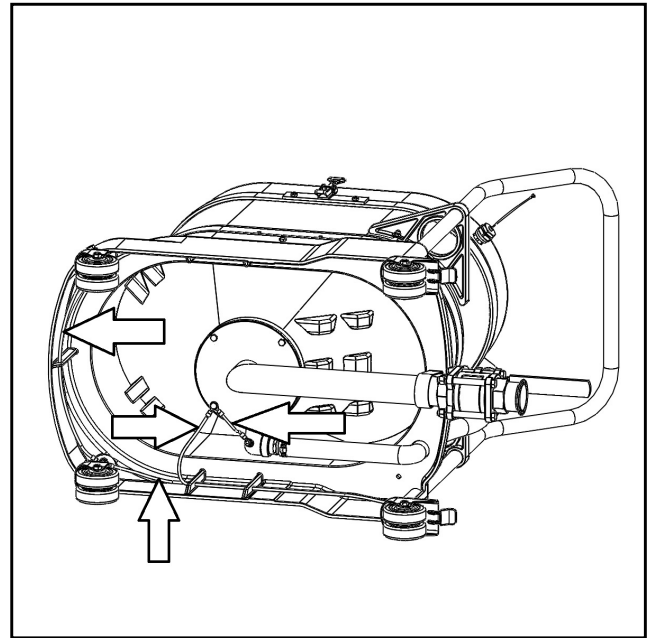

**(MX300 / MX300EX ONLY)  
FILTER MODULE - 4 WIRES**

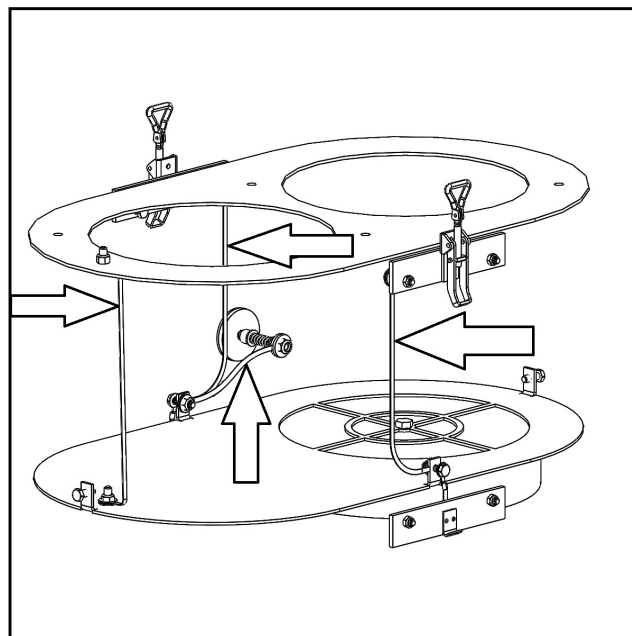

IV. \_\_\_\_\_ Inspection & Maintenance  
INSPECTION & MAINTENANCE OF MX300 / MX300EX / MX360 / MX360EX SERIES  
ELECTRICAL GROUNDING

**(MX360 / MX360EX ONLY)  
FILTER MODULE - 5 WIRES**

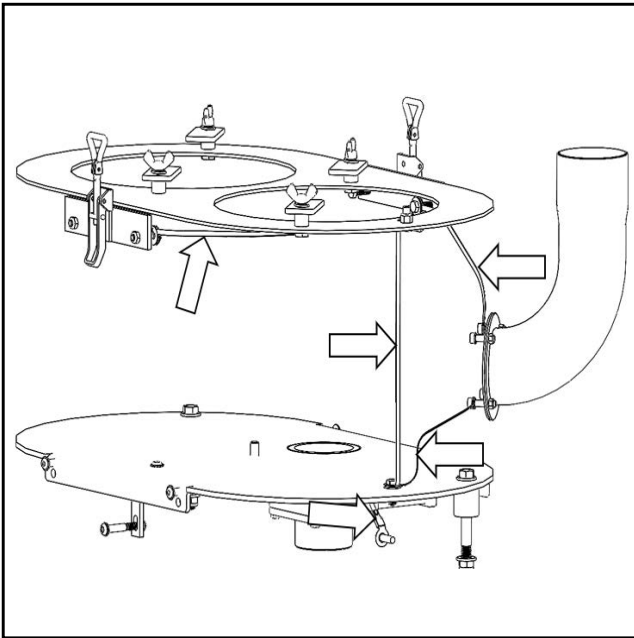

**(MX360 / MX360EX ONLY)  
DEMISTING ASSEMBLY - 2 WIRE**

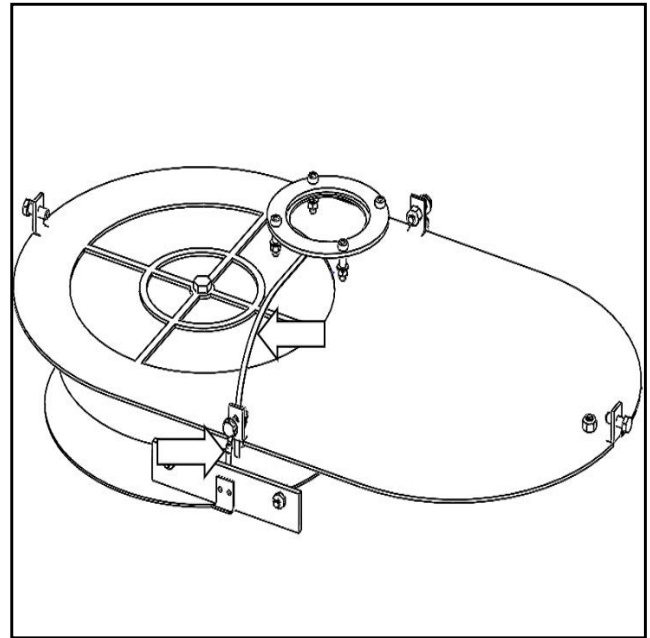

**(MX360 / MX360EX ONLY)  
IMMERSION BASE - 6 WIRES**

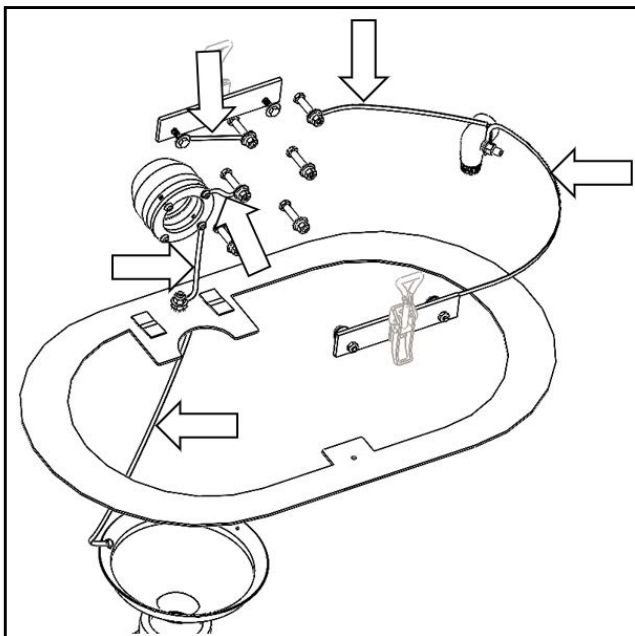

**MOTOR DECK - 3 WIRES**

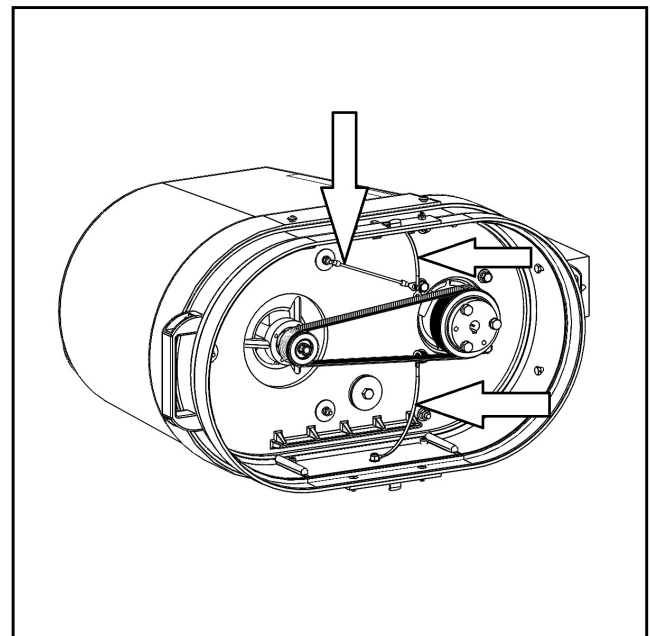



<b>PROBLEM</b>	<b>POSSIBLE CAUSE</b>	<b>CORRECTIVE ACTION</b>
<b>Water Leaked from Bottom Discharge</b>	- Seals leaking	- Check and replace if needed. Contact your Ruwac representative for replacement
<b>Insufficient Vacuum</b>	- Hose blocked	- Unplug hose.
	- Filter clogged or improperly seated	- Follow filter inspection procedure, Section V.
	- Vacuum leak	- Check that motor deck is properly seated and secured. Also, check all hoses.
<b>Air Leaks</b>	- Worn or poorly seated seals, Retainers improperly installed	- Block the inlet with a flat and rigid material to place the unit under vacuum pressure then remove retainers and turn the unit off. Inspect the seals for completeness, then reseal and secure components again under vacuum pressure.
<b>Unusual or High Pitched Noises</b>	- Motor bearings, turbine bearing	- Follow relevant motor / turbine inspection procedure, Section III. Check motor bearings for noise by hand.
	- Worn or poorly seated seals, Retainers improperly installed	- Block the inlet with a flat and rigid material to place the unit under vacuum pressure then remove retainers and turn the unit off. Inspect the seals for damage, then reseal and secure components again under vacuum pressure.
	- Belt worn, cracked, damaged	- Follow belt / turbine / motor inspection procedure, Section III.





## VI. \_\_\_\_\_ Terms & Conditions

**INSPECTION OF EQUIPMENT:** RUWAC shall have the right to inspect, after prior notices, the equipment supplied by it when in operation. If Buyer requires, RUWAC shall execute an appropriate secrecy agreement.

**CONFIDENTIALITY:** All proposals, drawings, diagrams, specification, pricing, and other materials relating to the goods included are the property and confidential information of RUWAC. Buyer shall not disclose such material or information without the written approval of RUWAC.

**BACK CHARGE:** RUWAC will pay claims for expenses of Buyer relating to labor and/or material supplied by Buyer only if (a) RUWAC is advise in writing before such expenses are incurred (2) RUWAC gives Buyer its prior written consent to the supply of such labor and/or material by buyer.

**LIMITED WARRANTY:** RUWAC warrants that new equipment which are complete units and are sold and/or manufactured by RUWAC, Inc. will be free from defects in material and workmanship for a period of 18 months from date of shipment or 12 months from date of start-up, whichever comes first. RUWAC warrants that replacement parts sold hereunder will be free from defects in material and workmanship for a period of 120-days after the date of shipment. RUWAC machines that have been completely re-built at the factory will carry a 180-day warranty from date of shipment. All field repairs by authorized RUWAC service personnel are covered by a 120-day parts only warranty. RUWAC, Inc. will not assume any responsibility under the terms of this limited warranty on equipment, which have not been paid for in full. This warranty does not apply to any equipment that has been disassembled, repaired, or otherwise altered by any person without the written authorization of RUWAC'S service department, nor does it apply to any product that has been subject to failure due to corrosive or abrasive attack, misused, damaged, or improperly installed, nor does it apply to motors, controls, and components not manufactured by RUWAC, Inc. Motors, controls, and other Sub vendor's components therefor are warranted only to the extent of the manufacturer's warranty. All warranty work on such products must be authorized by RUWAC, Inc. and must be performed in an authorized shop as designated by the manufacturer. RUWAC sole liability and buyer's sole and exclusive remedy hereunder is the replacement or repair at RUWAC'S option of products not complying with this warranty. Such repair or replacement shall be F.O.B. RUWAC'S factory, and RUWAC reserves the right to invoice all expenses incurred when repairs are made in the field at the request of the customer, except as specifically set forth herein, RUWAC makes no warranty express or implied, with respect to the products and/or service supplied hereunder, this warranty is in lieu of and excludes all other warranties, including without limitation, any warranty of merchantability, fitness for a particular purpose, or conformance to purchaser's specifications.

**LIMITATION OF LIABILITY:** RUWAC'S responsibility with respect to the goods and RUWAC'S obligations related thereto should in no event exceed the purchase price of the goods. RUWAC shall not be liable to Buyer for any special incidental, indirect, or punitive damages for any reason whatsoever, including, but without limitation damages in the form of (a) loss of profits, revenues, or anticipated savings resulting from the failure of the equipment to meet specifications or warranties (b) damages suffered by Buyer as a result of loss of production facilities or equipment (c) cost of replacement equipment (d) damages suffered by customers of the Buyer (e) any fines or penalties assessed for failure to comply with any law or government regulations.

**REPAIR OF GOODS EXPOSED TO HAZARDOUS, TOXIC, OR INFECTIOUS MATERIAL:** Buyer shall ensure that any goods submitted by Buyer or any of its customers to RUWAC for repairs or other service have been decontaminated and cleaned (including sterilization, if appropriate) of any hazardous, toxic or infectious materials, including without limitation any materials listed by the Environmental Protection Agency, OSHA, or any applicable state law as deserving or requiring special treatment. Upon RUWAC'S request, Buyer or its customer shall certify in writing that such goods contain no such hazardous, toxic, or infectious materials, and that such decontamination has taken place in accordance with accepted parties and in accordance with all applicable laws and regulations. If special safety equipment is required to protect RUWAC'S service personnel from any such hazardous, toxic, or infectious materials during field service work or otherwise. Buyer shall ensure that such safety equipment is provided and that the personnel are properly instructed. The provision of this paragraph shall apply to all work to be performed by RUWAC'S service personnel at any time, whether or not covered by warranty. Buyer shall defend and indemnify RUWAC for any and all losses, liabilities, expenses, and damages (including attorneys' fees) arising out of any failure of buyer or its customer to comply fully with the terms of this paragraph.

**BUYER SUPPLIED DATA:** Buyer acknowledges that RUWAC has relied upon all specifications and other data supplied by Buyer to RUWAC in the selection and design of the equipment and the preparation of this proposal. In the event the site operating conditions differ from those represented by Buyer and relied upon by RUWAC, any warranties or performance guarantees contained herein affected by such conditions shall be null and void, unless otherwise mutually agreed upon in writing.

## VI. \_\_\_\_\_ Terms & Conditions

**REMEDIES OF SELLER:** In addition to any other remedies of RUWAC provided hereby or by law, in the event Buyer becomes bankrupt, insolvent, assigns assets for the benefit of creditors or its financial condition has substantially deteriorated, RUWAC may, at its sole option, declare a breach of contract, stop all work hereunder or demand payments in advance as security for its performance hereunder.

**FACTIONS: GOVERNING LAW:** Any dispute, controversy, or claim against RUWAC with respect to the goods or any of RUWAC'S obligations related thereto must be commenced within one year from the date of shipment. All contract between Buyer and RUWAC shall be governed by and construed in accordance with the laws of the state of Massachusetts except that body of laws controlling conflict of laws.

**BONDS:** In addition to the price specified herein, Buyer shall pay the cost of any bonds, which Buyer requires RUWAC to obtain.

**ENTIRE AGREEMENT:** These terms and conditions, together with the provisions of the proposal constitute the entire agreement between the parties pertaining to the goods, and they supersede any prior or contemporaneous agreements, representations, or understandings between the parties. No waiver or modification of these terms and conditions is binding unless such waiver or modification is set out in writing signed by an authorized manager or officer of RUWAC. RUWAC'S failure to strictly enforce any right on one occasion does not constitute a waiver of that or any on any other occasion.

# HYDRO & OLEOPHOBIC MEDIA FILTER CLEANING

## **CAUTION:** YOU MAY CLEAN THE FILTER. HOWEVER, USE EXTREME CAUTION!

- Any abrasion to the surface will adversely affect filter's performance
- Do not use high-pressure water
- Do not use harsh brushes or similar devices
- Do not use oils, solvents or harsh detergents
- Do not use direct pressure on the dust side of the filter
- Wear appropriate clothing
- Properly contain and discard any residue generated while cleaning

## **DRY METHOD CLEANING**

- Pulse clean the cartridge off line (fan off), for 60 minutes with pulse frequency at 15-second intervals at 60 PSI or as close as you can come to those levels, given your equipment design. Pulse duration at 100 milliseconds.
- Remove the element from the unit and clean with a compressed air wand at 60 PSI. The size of the wand orifice needs to be 3/8" or larger to protect the filter.
- Move the wand up and down, covering the entire area of the filter element. If any contaminate is still visible on the outside (dust side) of the element, clean the outside with the air wand, moving parallel with the pleat at a 45 degree angle to the pleat surface at a sufficient distance away to avoid damage to the media. Try to remove the contaminant from the surface without forcing it into the pores of the filter. When finished, move the wand back to the interior and go over the interior one more time to remove any particulates that may have been forced into the pores from the dust side of cleaning.
- Inspect the clean air side if the collector for any dust buildup or damage and wear to the pulse system components. Clean or repair as necessary.
- Reinstall the units and note the pressure drop. If cleaning makes a significant reduction in the pressure drop and you have to perform manual cleaning frequency, please review your specific operating conditions with Ruwac.

## **WET METHOD CLEANING**

- Remove all excess dust as outlined above.
- Place the filters in a 2 - 3% solution (about 4 oz. per gallon) of mild dish washing soap and let the cartridge soak for 10 minutes.
- Remove the element and rinse the inside of the element with a garden hose, not to exceed 50 PSI. Thoroughly rinse all traces of detergent from both sides of the media.
- Rinsing outside needs to be done with a water stream at a 45 degree angle and parallel to the pleats.
- Let the element dry completely, normally 24 - 48 hours at 70 degrees F or higher. Do not dry in the collector with the fan. Filters must be completely dry before reuse.
- Reinstall the units and note the pressure drop. If cleaning makes a significant reduction in the pressure drop and you have to perform manual cleaning frequency, please review your specific operating conditions with Ruwac.
- NOTE: Hydro and oleophobic units are DESIGNED TO REPEL WATER AND OIL. Generally, water will not freely penetrate the media finish. This is normal and it means that the finish is working.

## DISPOSING ALUMINUM SLUDGE WASTE

When disposing aluminum sludge from a water-based wet collector such as a Ruwac immersion separator, the National Fire Protection Association has outlined a list of standards which operators should follow through their document NFPA 484: Standard for Combustible Metals 2015 Edition. According to section 9.4.12.7..., the following is the NFPA's recommended practices on how to safely contain, empty and dispose of sludge material:

- Sludge from water wet-type dust collectors should be removed at least once each day or more if usage and conditions require you to do so.
- Sludge should be collected in covered, vented metal containers during the transportation process.
- Disposal arrangements for sludge from wet-type dust collectors shall be planned in advance with the proper material handlers and follow all applicable federal, state and local regulations.
- Material removed from wet-type dust collectors is permitted to be mixed with inert materials such as sand and others nonreactive with aluminum) in a volume ration of five parts inert material to one part metal dust.
- The recycling or disposal of sludge should be in accordance with all federal, state and local regulations.
- Smoking or open flames on the disposal grounds should be prohibited during the disposal process.
- For more information on determining the characterization of your hazardous sludge waste, the NFPA points to 40 CFR 261 Subpart B of the Title 40 of Protection of Environment handbook.



## SERVICE ADVISORY:

# IS YOUR MX300 / MX360 SERIES BEING PROPERLY MAINTAINED?

Ruwac's MX300 / MX360 Series immersion separation vacuum systems are the most powerful and safest way to collect conductive metals, explosive and impact sensitive materials or glowing media. With 100% of the intake air being completely submerged in liquids, the chance of an outside ignition source entering the vacuum is safely ruled out. However, in order to ensure an efficient operation, users must do their part in properly maintaining and cleaning their machine of materials. Failure to do so can cause materials to build in the liquid tank over time. If that occurs, this renders your MX300 / MX360 defenseless against combustible dust saturation, potentially setting the stages for an explosion resulting in serious injury or even death.

## WHAT CAN YOU DO?

### 1. Proper Set-Up

- Ensure vacuum is properly grounded before and during each use.
- Use only Ruwac hoses and accessories.
- Determine which liquid should be used for your material based on the application. Fill the unit to the fill level on the sight glass before each use with the proper neutralizing liquid. Review the filling capacity regularly.
- Use only for the application the vacuum was purchased for according to the application worksheet that was sent when the vacuum was received.

### 2. Empty, clean and inspect your MX300 / MX360 Series unit

- Empty your MX300 / MX360 Series unit. It should be cleaned after each use to avoid material build-up and potential off-gassing.
- The demisting chamber and filters should be checked for excessive sediment build-up on a regular basis. Empty and take apart the unit to ensure there is no build up of material above the liquid bath. Clean the unit thoroughly.
- The demisting screen and the filters should be checked on a weekly basis to ensure efficiency.
- The sight glass window must be free from debris and offer visibility into the vacuum. Replace as required.  
\*Ensure that the fluid level hose is clear of any debris, especially at the bottom of the liquid tank.

### 3. Monitor material intake

- How long it takes for your MX300 / MX360 Series unit to fill with material depends upon the application and the amount of dust you are attempting to remove. Pay attention to time and quantity so that you can prevent picking up more material than your MX300 / MX360 Series can handle.

### 4. Monitor evaporation

- If your application is determined to use water as a neutralizer, it will evaporate during the usage of the unit. Check levels regularly and record the evaporation rate. Always maintain a proper liquid level. Special high and low water sensors and alarms are available as custom solutions. Contact Ruwac for details.

### 5. Set up a routine maintenance plan for your unit

- Once you have cleaned and inspected your MX300 / MX360 Series as well as monitored intake, set up a routine maintenance plan which all users shall abide by when operating the unit. This plan should make everyone aware of the MX300 / MX360's limits in order to safely keep them and your facility free of any potential accidents if proper maintenance is practiced.

## OTHER RECOMMENDATIONS

- Do not alter or repair vacuum without the written approval of Ruwac.
- Only authorized trained personnel should use the MX300 / MX360 Series unit. Use only as directed by Ruwac. Use only for the application the vacuum was purchased for as per the application worksheet that was sent with vacuum when vacuum was received.

