

Ruwac USA Industrial Vacuums

Workhorse-EX Series

Installation, Operation, Maintenance & Service

Model No.

Serial No.

Filter No.

Start-Up Date

• PORTABLE



Version: 2.3 3/12/24

Contents	Page
I. Warranty	3
II. Safety Instructions	4
III. Start-Up	7
IV. Inspection and Maintenance	
Standard Instructions (All Vacuums)	9
Silo Vacuum Instructions	20
V. Trouble Shooting	21
VI. Terms and Conditions	22

I. _____ **Warranty**

RUWAC warrants that new equipment which are complete units and are sold and/or manufactured by RUWAC, Inc. will be free from defects in material and workmanship for a period of 18 months from date of shipment or 12 months from date of start-up, whichever come first. RUWAC warrants that replacement parts sold hereunder will be free from defects in material or workmanship for a period of 120-days after the date of shipment. RUWAC machines that have been completely re-built at the factory will carry a 180-day warranty from date of shipment. All field repairs performed by authorized RUWAC service personnel are covered by a 120-day parts only warranty.

RUWAC, Inc. will not assume any responsibility under the terms of this limited warranty on equipment, which has not been paid in full. This warranty does not apply to any equipment that has been disassembled, repaired, or otherwise altered by any person without the written authorization of RUWAC'S service department, nor does it apply to any product that has been subjected to failure sure to corrosive or abrasive attack, misused, damaged, or improperly installed, nor does it apply to motors, controls, and components not manufactured by RUWAC, Inc. Motors, controls, and other Sub vendor's components therefor are warranted only to the extent of the manufacture's warranty. All warranty work on such products must be authorized by RUWAC, Inc. and must be performed in an authorized shop as designated by the manufacturer. RUWAC sole liability and buyer's sole and exclusive remedy hereunder is the replacement or repair at RUWAC'S option of products not complying with this warranty. Such repair or replacement shall be F.O.B. RUWAC'S factory, and RUWAC reserves the right to invoice all expenses incurred when repairs are made in the field at the request of the customer, except as specifically set forth herein, RUWAC makes no warranty express or implied, with respect to the products and/or service supplied hereunder, this warranty is in lieu of and excludes all other warranties, including without limitation, any warranty of merchantability, fitness for a particular purpose, or conformance to purchaser's specifications.

IMPORTANT SAFETY INSTRUCTIONS

When using an electrical vacuum system, basic precautions should always be followed, including the following:

READ ALL INSTRUCTIONS BEFORE USING THIS VACUUM

The Ruwac Workhorse-EX is designed for use in hazardous (classified) locations rated: Class I Group D, Class I Zone 1 Group IIA, Class II Groups F & G, Zone 21 Group IIIB, T3B/T3C, Max Ambient +40 C.

WARNING - To reduce the risk of fire, electric shock or injury:

1. Make sure that this vacuum is connected to the proper voltage, phase and frequency as stated on the equipment label.
2. Use only for the pickup of dry settled material. Do not use for the pickup of liquids.
3. Do not pick up ignition sources such as smoldering cigarettes, matches or hot ashes.
4. Insure that the ignition temperature of the material being vacuumed is above that of the operating temperature of the motor.
5. Pay special attention to the reactive properties of the material being vacuumed. Insure that the material is not reactive with other materials present in the machine or its materials of construction. Check your MSDS carefully for special hazards ie. Impact sensitivity.
6. Do not operate this vacuum with missing or damaged filters.
7. Inspect the vacuum for visible damage, especially to the power cord and cord cap. The vacuum must be removed from service and repaired prior to use.
8. Use only Ruwac replacement parts, accessories and hoses specifically designed for your machine.
9. Unplug the vacuum from the power source when not being used or when being serviced.
10. This vacuum is not supplied with a cord cap. The cord cap must be selected and installed by a qualified electrical technician. Insure that it is rated for the location, voltage, amperage and phase of the vacuum. Use only twist lock style cord caps.
11. The vacuum is supplied with a 30 foot power cord. An extension cord may be used if necessary, but be aware that adding an extension cord even one with the same rating as the power cord provided will result in voltage drop to the vacuum.
12. Connect to grounded dedicated circuits only.
13. Do not use the power cord to move this vacuum.
14. This vacuum is not designed for outside use or use in wet applications.
15. Hoses and accessories must be checked for continuity prior to each use when used in a hazardous application (i.e. combustible materials or environment).

SAVE THESE INSTRUCTIONS

WARNING:

The electrical service at the installation site must supply the voltage stamped on the machine's serial tag. Most motors have multiple voltage capabilities that may appear on the motor serial tag but do not apply to the specific machine.

Operating at an incorrect voltage may damage the machine. The machine should be connected to a dedicated fused service and properly grounded.

WARNING:

A qualified electrician in accordance to the NATIONAL ELECTRIC CODE and all local codes should perform all wiring and or electrical adjustments during installation and servicing.

1. Install the proper cord cap on the power cable, following the manufacturer's instructions. Insure that all terminal screws are properly tightened.
2. Start the machine by turning the selector to the ON position noting the motor direction. If the motor is turning in the wrong direction, shut the machine off by turning the selector to the OFF position. Have your electrician rewire the cord cap to correct the motor rotation.

WARNING:

When using the vacuum in another location, always verify motor rotation before placing the vacuum into service.

**WORKHORSE-EX SERIES STANDARD INSTRUCTIONS:
GROUNDING INSTRUCTIONS**

This appliance must be grounded. If it should malfunction or breakdown, grounding provides a path of least resistance for electrical current to reduce the risk of electric shock. This appliance is equipped with a cord having an equipment-grounding conductor and grounding plug. The plug must be inserted into an appropriate outlet that is properly installed and grounded in accordance with all local codes and ordinances.

Danger: Improper connection of the equipment-grounding conductor can result in a risk of electric shock. The conductor with insulation having an outer surface that is green with or without yellow stripes is the equipment-grounding conductor. If repair or replacement of the of the cord or plug is necessary, do not connect the equipment-grounding conductor to a live terminal. Check with a qualified electrician or serviceman if the grounding instructions are not completely understood, or if in doubt as to whether the appliance is properly grounded. Do not modify the plug provided with the appliance—if it will not fit the outlet, have a proper outlet installed by a qualified electrician.

This appliance is for use on a circuit having a nominal rating more than 120V and is factory equipped with a specific electrical cord and plug to permit connection to a proper electrical circuit. Make sure that the appliance is connected to an outlet having the same configuration as the plug. No adaptor should be used with this appliance. If the appliance must be reconnected for use on a different type of electrical circuit, the reconnection should be made by qualified service personnel; and after the reconnection, the appliance should comply with all local codes and ordinances.

Grounding Check

ABOUT RUWAC'S WORKHORSE-EX UNITS AND GROUND:

- All Workhorse-EX units are constructed of carbon impregnated compression cast composite hous-ings which dissipate static charge.
- Metal components are electrically grounded through a series of internal ground wires. Grounding can be confirmed using a standard multimeter.

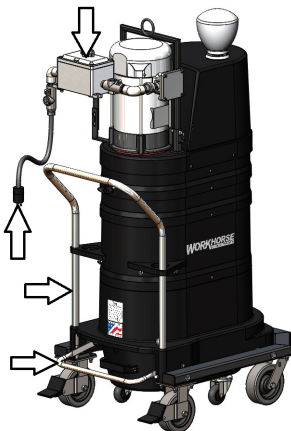

Check from continuity between the plug and handle bar, dustpan lever, and starter box if applicable.

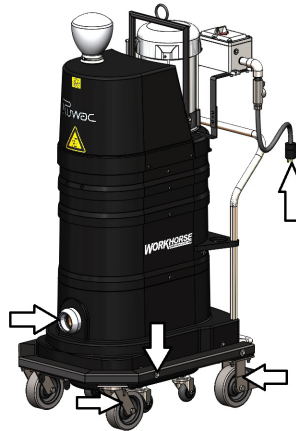

Also check for continuity between the plug and inlet, all four casters, and frame hardware if applicable.

Note: If continuity is not found across any of these points, consult the parts manual to check that all ground wires are in place. For further assistance, contact Ruwac.

WORKHORSE-EX SERIES STANDARD INSTRUCTIONS: START-UP / SHUT DOWN OPERATION

WARNING: A qualified electrician in accordance to the NATIONAL ELECTRIC CODE and all local codes should perform all wiring and or electrical adjustments during installation and servicing.



Pull up on the dust pan lever to release the dustpan. Check that the dustpan is completely empty, then replace.



Connect the machine to the proper power source as indicated on the machine's serial tag.

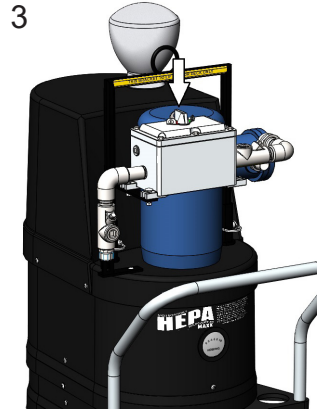

Turn motor on, then off quickly to confirm the motor is spinning in the correct direction.



Use the filter shaker to clean the filter before and after each use.



To empty the machine, release the dustpan lever.

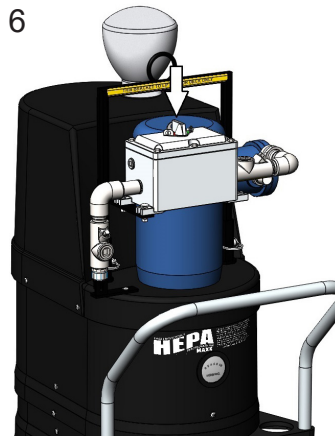

Turn on the motor before removing the dustpan. This will ensure that excess material sticks to the filter.



Remove the dustpan and empty contents. The dustpan should be emptied after every use.

**SEE PAGE 20 FOR
SILO VACUUM
EMPTYING
INSTRUCTIONS**

**WORKHORSE-EX SERIES STANDARD INSTRUCTIONS:
W155EX & W285EX SERIES START-UP OPERATION**

NOTE: W155EX's running at 70 PSI and 65 CFM must be used with a ½" NPT unrestricted air line.

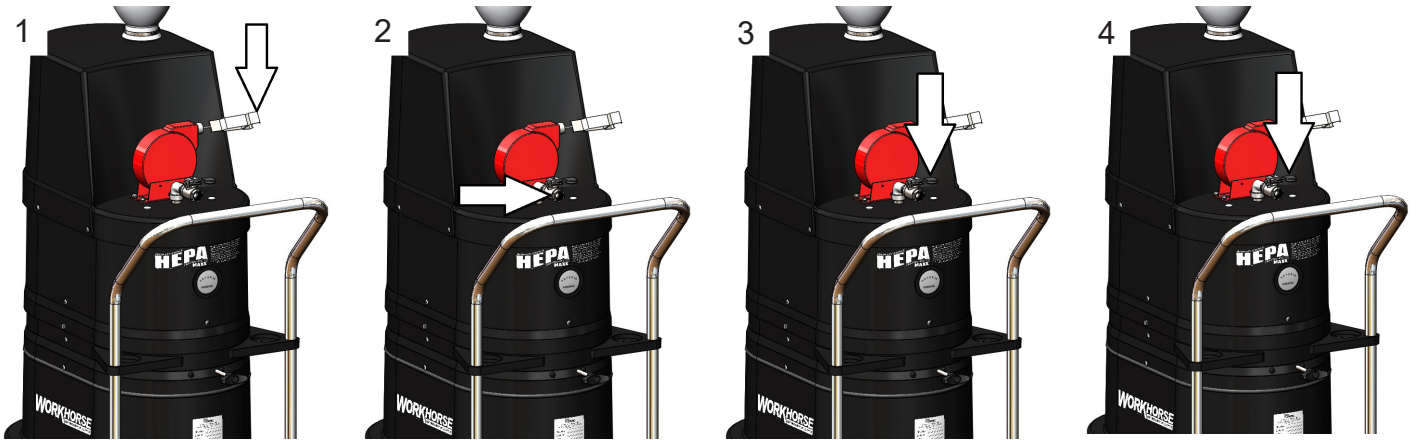

If included, affix the retractable grounding cable to an adequately grounded object.

Attach a full port air supply connection. A ½" unrestricted air line is required for optimal performance.

To turn on the machine, open the ball valve by turning the lever towards you.

To turn off the machine, close the ball valve by turning the lever away from you.

NOTE: W285EX's running at 100 PSI and 100 CFM must be used with a 1" NPT unrestricted air line.

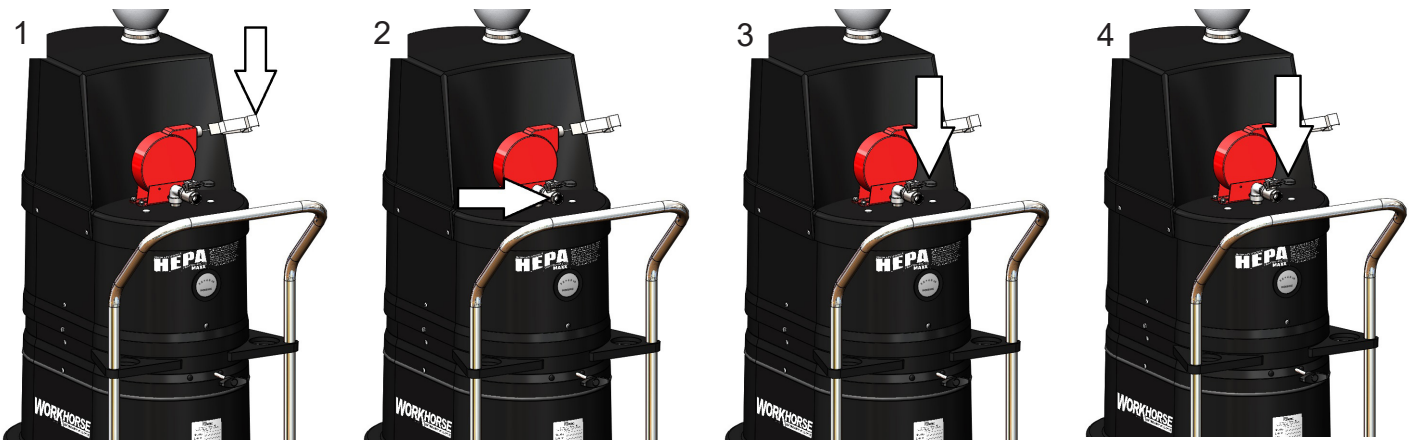

If included, affix the retractable grounding cable to an adequately grounded object.

Attach a full port air supply connection. A 1" unrestricted air line is required for optimal performance.

To turn on the machine, open the ball valve by turning the lever towards you.

To turn off the machine, close the ball valve by turning the lever away from you.

WORKHORSE-EX SERIES STANDARD INSTRUCTIONS: STANDARD FILTER INSPECTION

WARNING: Always wear a dust mask and have adequate help when performing filter inspections or service. Never try to inspect a filter on your own.



1 Use the shaker bar to clean the filter while the machine is off

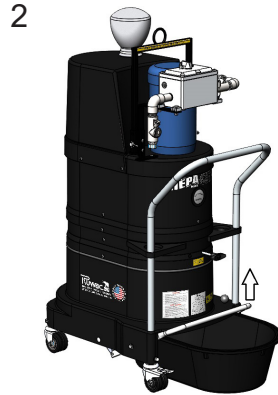

2 Pull up the lever and remove the dustpan

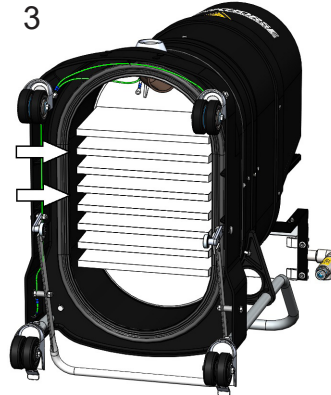

3 Lock the rear casters and carefully tip the machine back until it rests on the handle bar

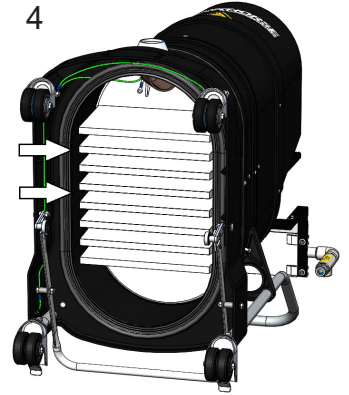

4 Clean the filter using another vacuum. Do not use any sharp tools.

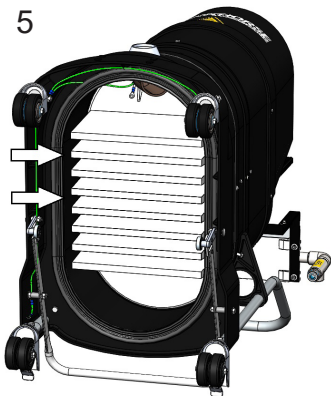

5 Inspect filter pleats for any tears or damage. Inspect the inlet deflector for wear as well



6 If the filter is damaged, it will have to be replaced. See pg. 10 for replacement instructions.



7 Push the dustpan back into the base.

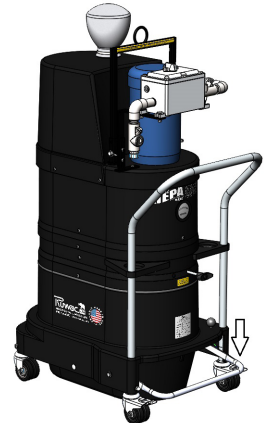

8 Push the lever down to secure the dustpan

Note: Using an object to dislodge material may tear the filter. Consult your RUWAC representative if material blockage is excessive. Do not use high pressure compressed air or water to clean off filter, as material may become permanently lodged into filter membrane.

**WORKHORSE-EX SERIES STANDARD INSTRUCTIONS:
FILTER REMOVAL**

CAUTION: Motor deck will be heavy and will require a hoist to remove. Always wear a dust mask when performing filter inspections or service.

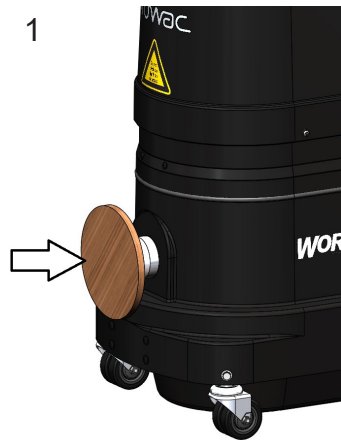

1
Turn vacuum on and block the inlet to place vacuum under pressure.



2
Remove all motor deck screws while the vacuum is under pressure. Turn off the vacuum after screws are removed



3
Remove the motor deck and silencer. Use the lifting bar if included.

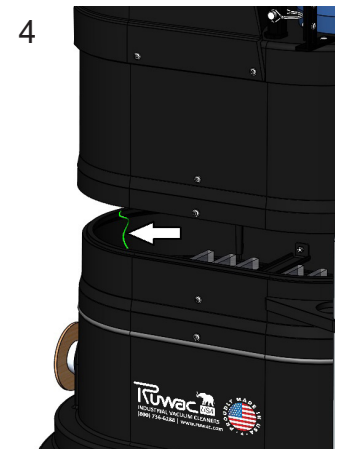

4
Disconnect the ground wire.

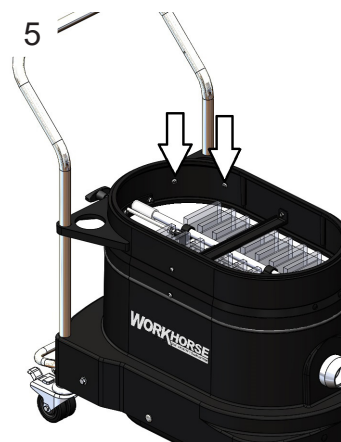

5
Remove the handle bar bracket hardware.

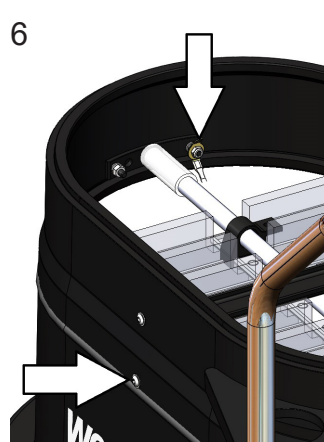

6
Disconnect the filter ground and remove the filter spacer hardware.



7
Remove the filter ring and shaker assembly.



8
Remove and replace the filter. Keep the black mesh inserts.

NOTE: The presence of material in this area or in the exhaust is often the result of a misaligned seal or damaged filter. Consult your RUWAC representative if either is the case.

WORKHORSE-EX SERIES STANDARD INSTRUCTIONS: FILTER INSTALLATION

CAUTION: Motor deck will be heavy and will require a hoist to remove. Always wear a dust mask when performing filter inspections or service.

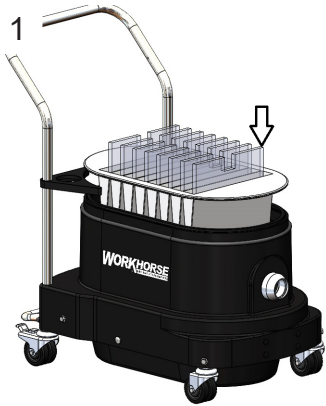

1 Reinsert black mesh inserts into the new filter.



2 Insert the filter cage into the filter pleats.

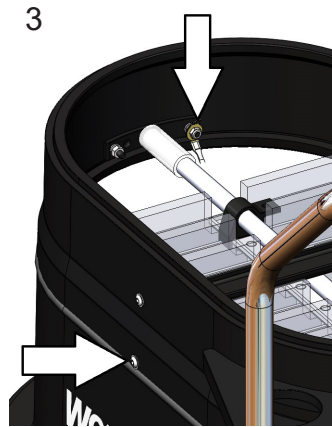

3 Insert the filter spacer hardware and reattach the ground wire.

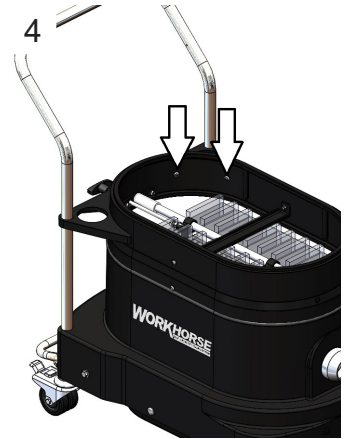

4 Install the handle bar bracket hardware.

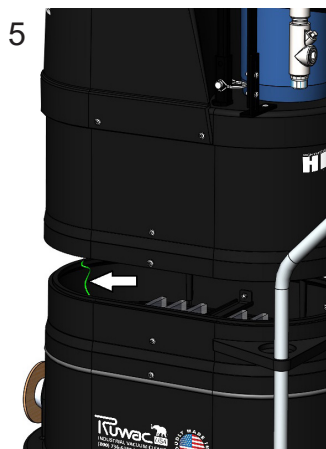

5 Reconnect the motor deck ground.



6 Replace the motor deck .

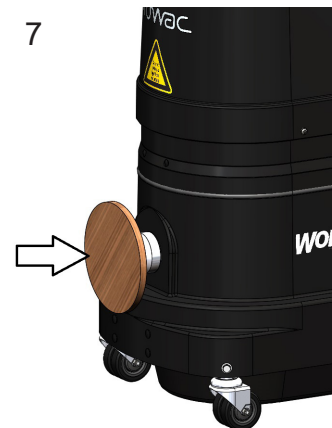

7 Place the vacuum under pressure by blocking the inlet and turning the machine on.



8 Reinstall the motor deck hardware.

WORKHORSE-EX SERIES STANDARD INSTRUCTIONS: HEPA MAXX FILTER MAINTENANCE

CAUTION: Motor deck will be heavy and will require a hoist to remove.



1
To ensure optimal performance of the HEPA Maxx filter, replace when the head loss reaches 8 inches of water column.



2
With motor running and inlet blocked, remove the motor deck hardware.



3
Remove the motor deck. Use the lifting bar if included. Disconnect the ground wire

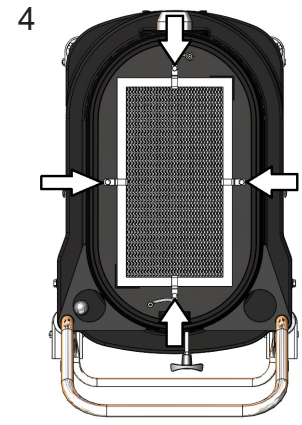

4
Loosen the bracket hardware.

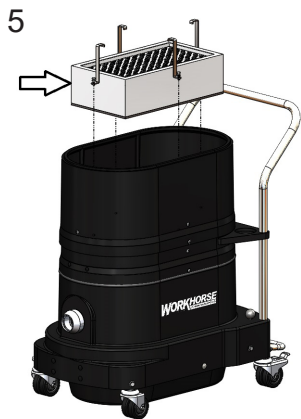

5
Remove and replace the HEPA filter.

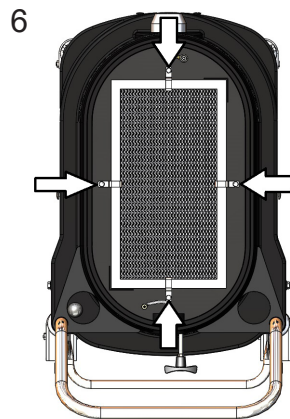

6
Tighten the bracket hardware.



7
Replace the motor deck, attach the ground wire.



8
With the motor running and inlet blocked, secure the motor deck hardware.

WORKHORSE-EX SERIES STANDARD INSTRUCTIONS: HEPA MAXX FILTER FIELD INSTALLATION

CAUTION: Motor deck will be heavy and will require a hoist or two users to place atop work bench or table.



1 Remove the motor deck hardware.



2 Remove the motor deck. Disconnect the ground wire.

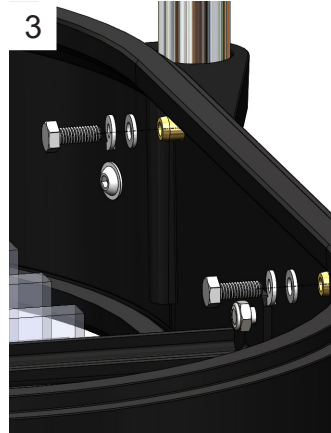

3 Insert M6 screws into the back of PEMs.

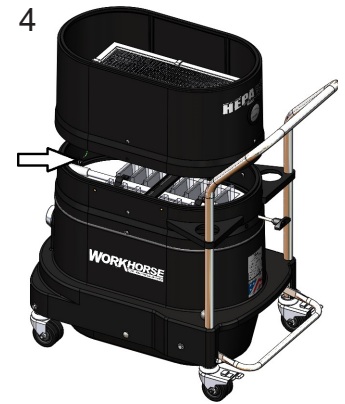

4 Place the HEPA module on machine and connect ground wire.



5 Place the motor deck on top of the HEPA module and connect the ground wire.



6 Turn on the motor and block the inlet.



7 Drill holes into the housing with an 5/16in bit at the 6 locations pointed out above.



8 Remove the motor deck. Drill holes with a 1/2in bit at the 4 locations pointed out above.

WORKHORSE-EX SERIES STANDARD INSTRUCTIONS: HEPA MAXX FILTER FIELD INSTALLATION

CAUTION: Motor deck will be heavy and will require a hoist or two users to place atop work bench or table.



Remove the HEPA module. Drill holes with a 1/2in bit at the 2 locations point out above.



Insert rubber PEMs at the 6 locations pointed out above.



Replace the moto deck and connect the ground.



Replace the silencer.



Block the inlet and turn on the vacuum.



Insert 1/4-20 bolts with lock washers into the 6 locations pointed out above.



Completed unit as shown.

WORKHORSE-EX SERIES STANDARD INSTRUCTIONS: BELT INSPECTION

CAUTION: Motor deck will be heavy and will require a hoist to remove. Before any maintenance service is done, follow standard lock out and tag out procedures as well.

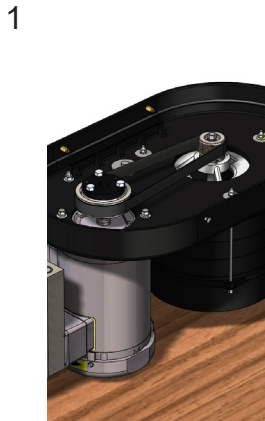

With power disconnected, remove the motor deck. Place the motor deck upside-down on a clean working surface.

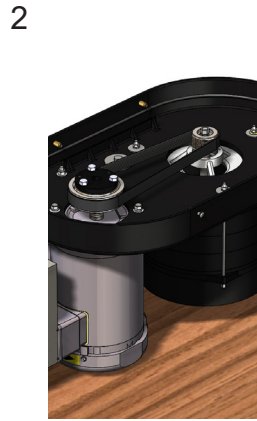

Inspect the belts for any glazing, cracking or shredding. Any of these will require belt replacement. (See below)

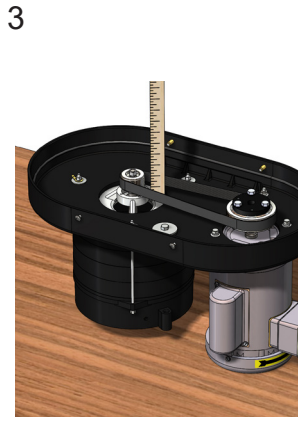

Check that sheaves are properly aligned. (See pg. 19 for pulley alignment instructions)



Check tension using a straight edge and tension gauge as shown above. (See pg. 18 for belt tensioning instructions)

REPLACING THE BELT



To replace a drive belt, first cut and remove silicone around turbine.

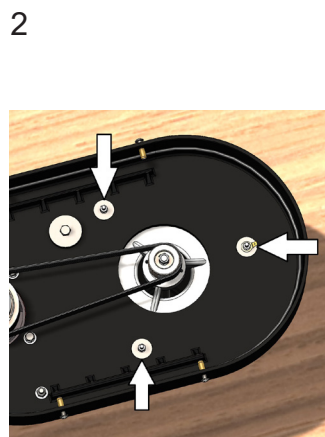

Loosen the turbine hardware, then slide turbine towards the motor to loosen the belt.



Remove old belt and replace with new one.

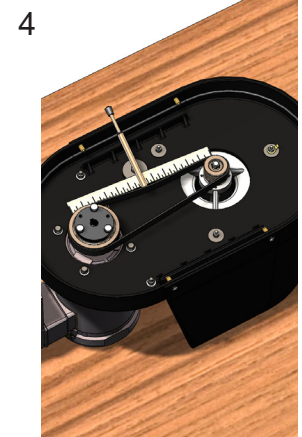

Properly tension belt by following belt tensioning instructions on pg. 18.

WORKHORSE-EX SERIES STANDARD INSTRUCTIONS: TURBINE REPLACEMENT

NOTE: The turbine is not field serviceable and must be replaced as one unit if defective. Replacement of the motor belt or turbine will require the turbine seal to be replaced.



Switch the vacuum off and remove the power cord from the power source.



Remove the vacuum from the hazardous area to a service work area where the motor deck can be rested on a work bench or table.



Remove the silencer assembly from the motor deck.

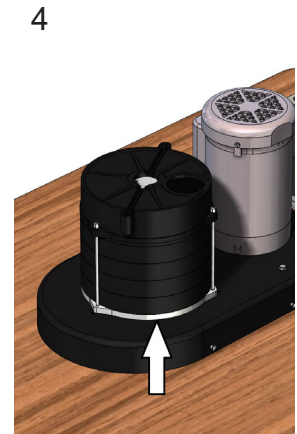

Break the silicone seal surrounding turbine using a sharp edge.

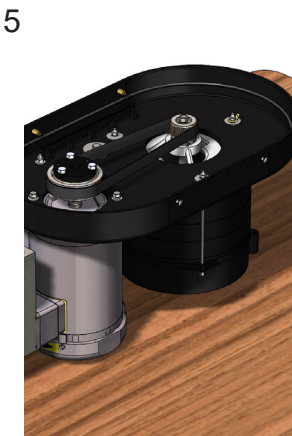

Carefully turn motor deck upside down onto work bench or table.

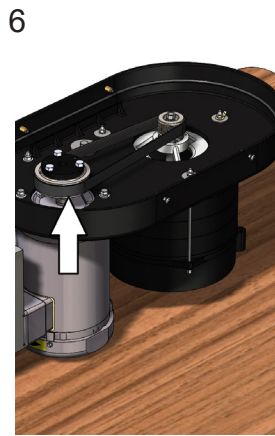

Remove belt by walking it off.

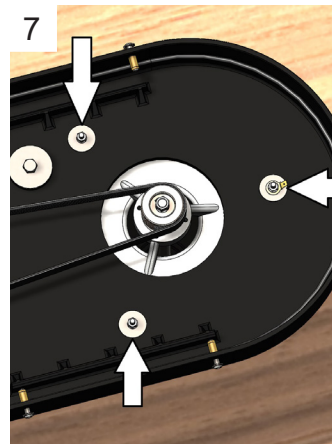

Loosen the three nuts securing the turbine, supporting it from underneath to ensure it doesn't drop.

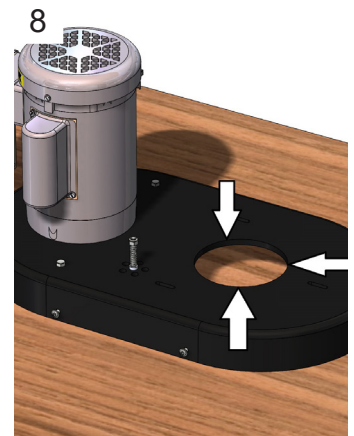

Using a sharp edge, remove the remaining silicone seal from the motor deck.

CAUTION: Motor deck will be heavy and will require a crane to place atop work bench or table.

**WORKHORSE-EX SERIES STANDARD INSTRUCTIONS:
TURBINE REPLACEMENT**

9

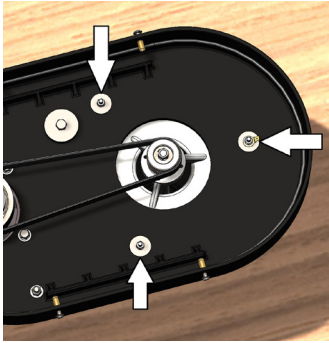

Replace turbine by fastening all nuts and bolts through bottom of motor deck.

10

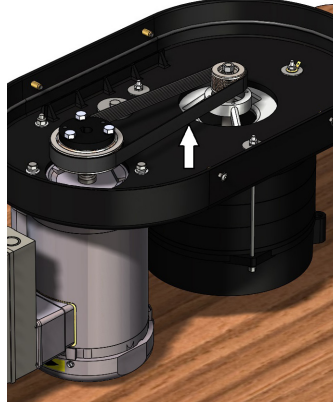

Align and install new motor belt (See pg. 15 for instructions).

11

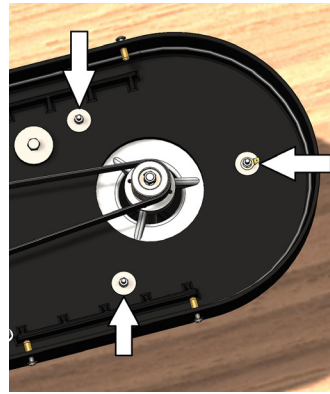

Tighten all nuts and bolts surrounding turbine to ensure they're fastened snug securely. Do not overtighten.

12



Flip fully assembled motor deck upright, resting front end on a support so as not to move underlying bushing and belt.

13

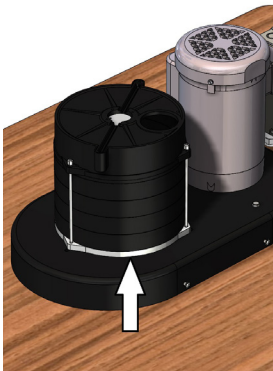

Reapply silicone, and let sit it for 2 hours or until dry (not tacky).

CAUTION: Motor deck will be heavy and will require a crane to place atop work bench or table.

**WORKHORSE-EX SERIES STANDARD INSTRUCTIONS:
BELT TENSIONING**

CAUTION: Motor deck will be heavy and will require a hoist to remove. Before any maintenance service is done, follow standard lock out and tag out procedures as well.

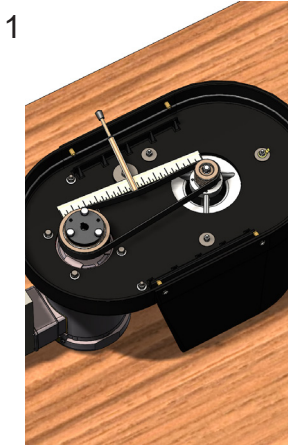

1 Measure belt tension by using a straight edge and tension gauge as shown above. Refer to diagram below for proper tension specifications.

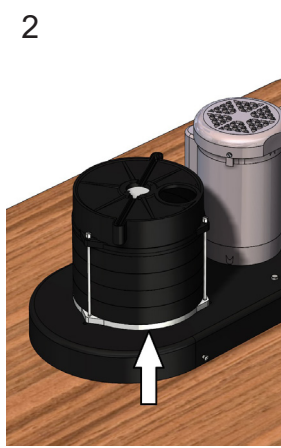

2 To tighten belt, slide turbine away from the motor. Before sliding the turbine, the silicone on the top of the motordeck must be cut and removed.

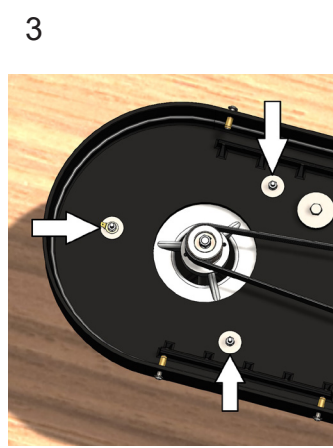

3 After removing the silicone, loosen the turbine hardware and adjust the turbine position as necessary.

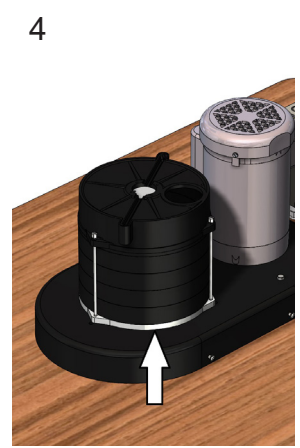

4 Once the belt has been properly tensioned, secure the hardware and re-seal the turbine with silicone.

New 6-groove belts should be set to 6lbs at 3/16" of deflection. New 10-groove belts should be set to 9lbs at 3/16" of deflection. Allow new belts to stretch by running in for several hours. After run-in period, 6-groove belts should be between 4lbs to 5lbs, and 10-groove belts should be between 7lbs to 8lbs.

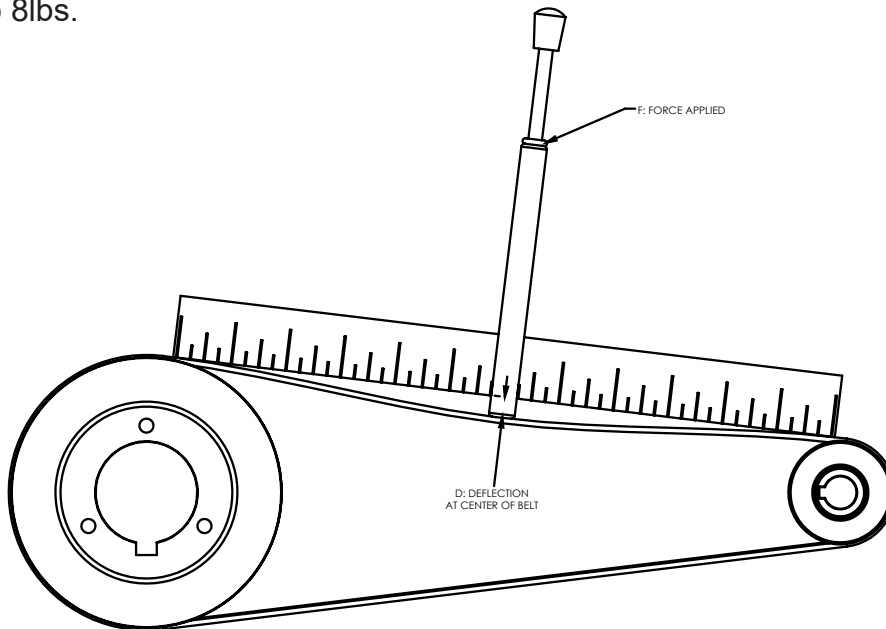

WORKHORSE-EX SERIES STANDARD INSTRUCTIONS: PULLEY ALIGNMENT

NOTE: Complete the previous operations to prepare the motor deck for service of the motor, turbine or belt. Replace any defective components and secure the motor with bolts before proceeding.

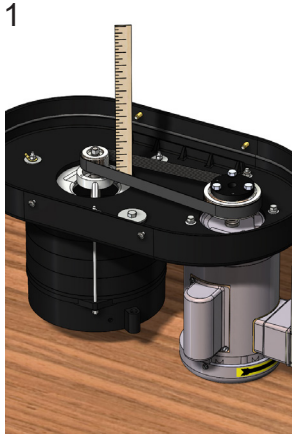

Measure the height of the first groove on the turbine sheave. Check that the first groove of the motor sheave matches this height.

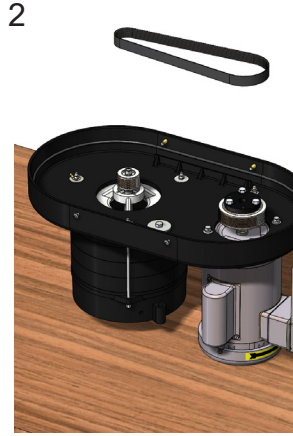

If motor sheave needs adjustment, remove belt and adjust motor sheave. (See pg. 15 for belt removal instructions)

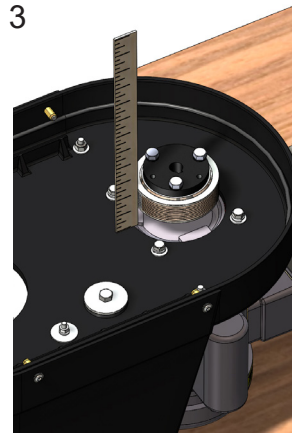

Loosen motor sheave hardware, and slide up or down as necessary.

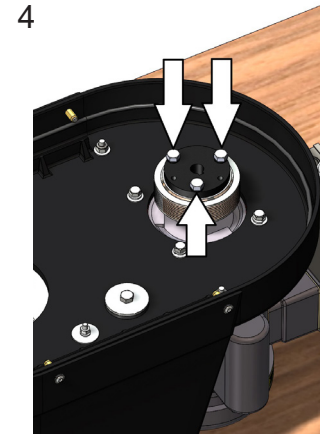

Once motor sheave is at correct height, tighten bolts to 15 ft-lbs of torque.

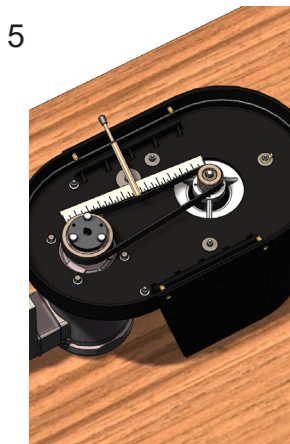

Re-install the belt and adjust to proper tension. (See pg. 18)

WORKHORSE-EX SERIES SILO VACUUM SERIES INSTRUCTIONS: SILO DRUM RELEASE & EMPTYING

The Silo System drum is comprised of two locking pins located on each side of the bars attached to the drum lid of the silo. Each locking pin has a black ball handle for release, and each can be inserted into the designated guide to securely position the lid in the upward (open) and downward (closed) positions. When the drum lid is fixed in the upward position, it allows for the removal and emptying of the drum caddy from underneath the silo system.



1
Standing on either side of the machine, grab the ball pin lock and pull it out of the guide.



2
Once ball pin is released, pull up on the guide bar until it locks in the upward position, making sure the ball pin clicks into its designated hole.



3
Repeat the process for the other side.



4
Once both pins and lid are locked in the up position, remove the drum by rolling the caddy unit from under the silo.



Note: To reattach, place drum underneath silo, release the locking pins on each side, and allow the lid to lower onto the drum.

PROBLEM	POSSIBLE CAUSE	CORRECTIVE ACTION
Insufficient Vacuum Pressure	- Motor in wrong direction	- Check motor direction and ensure it is moving clockwise.
	- Dustpan improperly seated	- Remove dustpan, inspect seal, replace dustpan.
	- Filter clogged or improperly seated	- Follow filter inspection procedure (Section IV.)
	- Clogged hose	- Remove hose and re-inspect vacuum pressure, if vacuum pressure returns to normal snake hose.
	- Unit is improperly sealed	- Block the inlet with a flat and rigid material to place the unit under vacuum pressure then inspect for air leaks.
Air Leaks	- Worn or poorly seated seals, Retainers improperly installed	- Block the inlet with a flat and rigid material to place the unit under vacuum pressure then remove retainers and turn the unit off. Inspect the seals for completeness, then reseal and secure components again under vacuum pressure.
Material In Exhaust / On Top Side of Filter	- Poor filter seal or torn filter	- Follow filter inspection procedure (Section IV.)
Unusual or High Pitched Noises	- Motor bearings, turbine bearing	- Follow relevant motor bushing inspection procedure (Section IV.) Check motor bearings for noise by hand.
	- Worn or poorly seated seals, Retainers improperly installed	- Block the inlet with a flat and rigid material to place the unit under vacuum pressure then remove retainers and turn the unit off. Inspect the seals for damage, then reseal and secure components again under vacuum pressure.
	- Belt worn, cracked, damaged, stretched, loose	- Follow belt / turbine / motor inspection in previous pages
Vacuum Motor Shuts Down Prematurely	- Confirm the amperage setting on motor overload	

VI. _____ Terms & Conditions

ACCEPTANCE: The terms and conditions of sale set forth herein apply to any order accepted or acknowledged by RUWAC, Inc. Buyer's acceptance of RUWAC'S proposal or delivery of all or any part of the goods covered hereunder constitutes acceptance of the terms and conditions of sale contained herein, and RUWAC hereby rejects any additions to or modification to these terms and conditions. Any representations, promises, warranties, or statements by RUWAC or its agents that differ in anyway from these terms and conditions shall be given no force or effect. No contract is final until accepted in writing by RUWAC at its corporate office in Holyoke, Massachusetts.

PRICES: Prices quoted orally expire the same day they are made unless accepted in writing on that day or confirmed by written communication by RUWAC. Written price quotations are guaranteed for thirty (30) days after the date issued, but may be terminated by written notice within that period. After thirty (30) days, any written price quotations are subject to adjustment to reflect prices in effect at the time of shipment, including any changes in packing, storage, or shipping charges. This order or proposal includes only the equipment specified herein, and does not include freight or installation of RUWAC equipment. All prices are F.O.B. RUWAC'S plant in Holyoke, Massachusetts and are exclusive of all taxes, levies, and duties that may be assessed in connection with the sale or delivery of goods, and Buyer shall be responsible for all such taxes, levies, and duties. In the event RUWAC pays any such tax, levy, or duty, Buyer shall promptly reimburse RUWAC therefor. Any packaging requirements other than RUWAC'S standard packaging and commercial container will be invoiced as an extra charge.

PAYMENT: Payment is due in full thirty (30) days after the date of invoice. All invoices paid after the due date will be assessed a late payment charge of one and half percent (1.5%) per month or any portion thereof, or the maximum amount allowed by applicable law, whichever is less. Buyer shall be responsible for all costs of collection, including reasonable legal fees. Sales on the foregoing terms are subject to the approval of RUWAC'S credit department and may be changed at any time at RUWAC'S sole discretion. If RUWAC has reasonable grounds with respect to Buyer's ability or willingness to make timely payments for the goods. RUWAC may at any time suspend performance, decline to ship, or require advance payment in cash or other adequate assurance satisfactory to RUWAC.

SHIPMENTS AND DELIVERY: RUWAC shall use its reasonable efforts to meet all shipment or delivery dates recited in RUWAC'S proposal or in Buyer's order but any such dates are estimated only and are not guaranteed. RUWAC shall have no liability to Buyer for damages or penalties, direct or indirect, for any delay in shipment or delivery, whether such delay is minor or substantial, nor shall Buyer have the right to declare a breach of contract because of any such delay. In any event, delivery schedules are based upon the effective date of the order and are subject to prompt receipt by RUWAC of all necessary down payments, information and instructions from Buyer, including any required approval of drawings. RUWAC shall have the right to make partial shipments, and invoiced covering the same shall be payment terms hereof. RUWAC will attempt to ship in accordance with Buyer's instructions, but RUWAC will make the final selection of a method of shipment and a carrier unless Buyer clearly and conspicuously specifies that shipment must be by a particular method of carrier. RUWAC is not responsible for damage or loss in transit, and all such claims must be by Buyer directly against the carrier.

CHANGE ORDERS: RUWAC shall not be obligated to make any changes in or additions to the scope of the work which are initiated by Buyer or result from circumstances beyond RUWAC'S control unless there is an equitable adjustment in price and or delivery.

CANCELLATION, SUSPENSION OR DELAY: In the event Buyer requests or causes a cancellation, suspension or delay in any RUWAC'S work under this proposal or order based thereon, Buyer shall indemnify and pay to RUWAC all appropriate charges, including but not limited to any costs, expenses, and commitments incurred by RUWAC up to the date of receipt of notice of such cancellation, suspension or delay, plus RUWAC'S overhead and reasonable profit. If shipment is delayed on account of Buyer, the purchase price shall be due and payable as if delivery had been made. Additionally, all charges related to storage, disposition and/or resumption of work, at RUWAC'S plant or elsewhere, shall be for Buyer's sole account and Buyer thereto shall assume all risks incidental.

CLAIMS: NOTICE OF DEFECTS: Buyer shall give written notice of rejection of any shipment or portion thereof within thirty (30) days after the date of shipment specifying the reasons therefor. Failure to give such notice shall be deemed a waiver of any right of rejection and any claim with respect thereto (except as to claims under the warranty) and shall be deemed an acceptance of such shipment. Buyer shall set aside and hold rejected goods without further processing until RUWAC has an opportunity to inspect and advise of the disposition, if any, to be made of such goods. In no event shall any rejected goods be returned reworked, or scrapped by Buyer without the express written authorization of RUWAC.

VI. _____ Terms & Conditions

INSPECTION OF EQUIPMENT: RUWAC shall have the right to inspect, after prior notices, the equipment supplied by it when in operation. If Buyer requires, RUWAC shall execute an appropriate secrecy agreement.

CONFIDENTIALITY: All proposals, drawings, diagrams, specification, pricing, and other materials relating to the goods included are the property and confidential information of RUWAC. Buyer shall not disclose such material or information without the written approval of RUWAC.

BACK CHARGE: RUWAC will pay claims for expenses of Buyer relating to labor and/or material supplied by Buyer only if (a) RUWAC is advise in writing before such expenses are incurred (2) RUWAC gives Buyer its prior written consent to the supply of such labor and/or material by buyer.

LIMITED WARRANTY: RUWAC warrants that new equipment which are complete units and are sold and/or manufactured by RUWAC, Inc. will be free from defects in material and workmanship for a period of 18 months from date of shipment or 12 months from date of start-up, whichever comes first. RUWAC warrants that replacement parts sold hereunder will be free from defects in material and workmanship for a period of 120-days after the date of shipment. RUWAC machines that have been completely re-built at the factory will carry a 180-day warranty from date of shipment. All field repairs by authorized RUWAC service personnel are covered by a 120-day parts only warranty. RUWAC, Inc. will not assume any responsibility under the terms of this limited warranty on equipment, which have not been paid for in full. This warranty does not apply to any equipment that has been disassembled, repaired, or otherwise altered by any person without the written authorization of RUWAC'S service department, nor does it apply to any product that has been subject to failure due to corrosive or abrasive attack, misused, damaged, or improperly installed, nor does it apply to motors, controls, and components not manufactured by RUWAC, Inc. Motors, controls, and other Sub vendor's components therefor are warranted only to the extent of the manufacturer's warranty. All warranty work on such products must be authorized by RUWAC, Inc. and must be performed in an authorized shop as designated by the manufacturer. RUWAC sole liability and buyer's sole and exclusive remedy hereunder is the replacement or repair at RUWAC'S option of products not complying with this warranty. Such repair or replacement shall be F.O.B. RUWAC'S factory, and RUWAC reserves the right to invoice all expenses incurred when repairs are made in the field at the request of the customer, except as specifically set forth herein, RUWAC makes no warranty express or implied, with respect to the products and/or service supplied hereunder, this warranty is in lieu of and excludes all other warranties, including without limitation, any warranty of merchantability, fitness for a particular purpose, or conformance to purchaser's specifications.

LIMITATION OF LIABILITY: RUWAC'S responsibility with respect to the goods and RUWAC'S obligations related thereto should in no event exceed the purchase price of the goods. RUWAC shall not be liable to Buyer for any special incidental, indirect, or punitive damages for any reason whatsoever, including, but without limitation damages in the form of (a) loss of profits, revenues, or anticipated savings resulting from the failure of the equipment to meet specifications or warranties (b) damages suffered by Buyer as a result of loss of production facilities or equipment (c) cost of replacement equipment (d) damages suffered by customers of the Buyer (e) any fines or penalties assessed for failure to comply with any law or government regulations.

REPAIR OF GOODS EXPOSED TO HAZARDOUS, TOXIC, OR INFECTIOUS MATERIAL: Buyer shall ensure that any goods submitted by Buyer or any of its customers to RUWAC for repairs or other service have been decontaminated and cleaned (including sterilization, if appropriate) of any hazardous, toxic or infectious materials, including without limitation any materials listed by the Environmental Protection Agency, OSHA, or any applicable state law as deserving or requiring special treatment. Upon RUWAC'S request, Buyer or its customer shall certify in writing that such goods contain no such hazardous, toxic, or infectious materials, and that such decontamination has taken place in accordance with accepted parties and in accordance with all applicable laws and regulations. If special safety equipment is required to protect RUWAC'S service personnel from any such hazardous, toxic, or infectious materials during field service work or otherwise. Buyer shall ensure that such safety equipment is provided and that the personnel are properly instructed. The provision of this paragraph shall apply to all work to be performed by RUWAC'S service personnel at any time, whether or not covered by warranty. Buyer shall defend and indemnify RUWAC for any and all losses, liabilities, expenses, and damages (including attorneys' fees) arising out of any failure of buyer or its customer to comply fully with the terms of this paragraph.

BUYER SUPPLIED DATA: Buyer acknowledges that RUWAC has relied upon all specifications and other data supplied by Buyer to RUWAC in the selection and design of the equipment and the preparation of this proposal. In the event the site operating conditions differ from those represented by Buyer and relied upon by RUWAC, any warranties or performance guarantees contained herein affected by such conditions shall be null and void, unless otherwise mutually agreed upon in writing.

VI. _____ Terms & Conditions

REMEDIES OF SELLER: In addition to any other remedies of RUWAC provided hereby or by law, in the event Buyer becomes bankrupt, insolvent, assigns assets for the benefit of creditors or its financial condition has substantially deteriorated, RUWAC may, at its sole option, declare a breach of contract, stop all work hereunder or demand payments in advance as security for its performance hereunder.

FACTIONS: GOVERNING LAW: Any dispute, controversy, or claim against RUWAC with respect to the goods or any of RUWAC'S obligations related thereto must be commenced within one year from the date of shipment. All contract between Buyer and RUWAC shall be governed by and construed in accordance with the laws of the state of Massachusetts except that body of laws controlling conflict of laws.

BONDS: In addition to the price specified herein, Buyer shall pay the cost of any bonds, which Buyer requires RUWAC to obtain.

ENTIRE AGREEMENT: These terms and conditions, together with the provisions of the proposal constitute the entire agreement between the parties pertaining to the goods, and they supersede any prior or contemporaneous agreements, representations, or understandings between the parties. No waiver or modification of these terms and conditions is binding unless such waiver or modification is set out in writing signed by an authorized manager or officer of RUWAC. RUWAC'S failure to strictly enforce any right on one occasion does not constitute a waiver of that or any on any other occasion.